



### Table of Contents

#### Introduction

Terms and Conditions	2
General Specifications	5
Materials & Finish Palette	7

#### Conference Tables

Table Specifications	10
Rectangular Conference Tables	14

#### Media Tables

Media Table Specifications	24
Rectangular Media Tables	28
Trapezoid Media Tables	40

#### Waterfall Tables

Waterfall Table Specifications	46
Counter Height Waterfall Tables	54
Bar Height Waterfall Tables	55

#### Credenzas

Credenza Specifications	58
Bookcase	68
3 Position Credenza	69
4 Position Credenza	71
5 Position Credenza	73
Credenza Inserts	75

#### Accessories

Power & Connectivity	81
----------------------	----

# Terms and Conditions of Sale

Sales by DatesWeiser (hereinafter called the Seller) are made only on the terms and conditions set forth below. These terms and conditions may be modified or supplemented only by a written document signed by an authorized representative of the Seller. These terms and conditions supersede any prior and/or contemporaneous agreements or correspondence between Purchaser and Seller.

## Ordering Information

All orders must be in writing.

A Purchase Order is not binding on the Seller until Purchaser has received Seller's Order Confirmation.

## Pricing Policies

All written quotations expire thirty (30) days from the date of issuance and can be withdrawn by written notice anytime during that period.

Prices are List, F.O.B. from the DatesWeiser factory in Buffalo, New York. Shipping, packaging, inside delivery, uncrating, installation, storage, and sales tax (if applicable) shall be in addition to the list price and shall be itemized and charged separately.

List prices are subject to change without notice.

List prices shall be those prices in effect on the date the Seller receives a completed Purchase Order unless shipment is requested more than 120 days after the order entry, in which case prices in effect on the date of shipment apply.

## Taxes

All sales, use, excise, and other taxes applicable to the sale of DatesWeiser Products shall be paid by the Purchaser. To claim an exemption from any tax, Purchaser must submit to Seller the appropriate exemption certificates.

## Terms of Payment

A fifty percent (50%) deposit is due at the time of order placement and the remainder due within thirty (30) days of the date of invoice.

If, in the judgment of Seller, Purchaser's financial condition does not justify the terms of the payment, Seller may require full or partial payment in advance.

The ship date the Seller specifies is considered the invoice date for billing. The ship date will be confirmed by the Seller via a separate Acknowledgement issued upon receipt of a signed Purchase Order.

Past due accounts shall be charged one and one-half percent (1.5%) per month, or the highest rate permitted by law, which-ever is less, and will be added to the outstanding balance. In the event Purchaser defaults on payment, Purchaser shall be liable for all collection costs, including reasonable attorney's fees and costs.

## Changes and Cancellations

A confirmed order may not be changed or cancelled, in whole or in part, without prior written consent of Seller. Changes may effect delivery dates. Expenses incurred because of changes shall be charged to Purchaser. In event of cancellations, Purchaser will be liable for reasonable cancellation charges, including a \$500 administrative fee.

Seller is not required to comply with Purchaser's request to change a confirmed order, but all reasonable requests to change confirmed orders will be honored. Orders for special or custom Product may not be cancelled.

To be effective, a Change Order must be in writing, signed by the Purchaser or Purchaser's agent, and confirmed in writing by the Seller. Change Orders are subject to a charge for materials, labor, and other costs as determined by Seller.

## Security Interest

Until Seller receives the full payment for the Product, Seller shall have a security interest in the Product. Purchaser agrees to perform all acts, including but not limited to the execution and filing of documentation, which may be necessary to perfect and assure the security interest of Seller.

## Customer's Own Material (COM)

A Purchaser who requests a material not standard to Seller's line of Products must submit a sample of the requested material to Seller prior to entry of a purchase order. Seller shall determine if the material is suitable to its manufacturing processes and meets any requirements of Underwriter Laboratories. If the COM is acceptable, Seller will then establish a price for using the COM on the Product in question.

## Custom Finish Match

For custom wood or paint finishes add \$1,032 net per finish. This is a one-time matching charge. Custom finishes may extend delivery time up to four (4) weeks. Control samples of custom finishes will be provided.

---

**Hardware**

Final adjustment of furniture hardware such as hinges, drawer slides, drawer pulls, etc., at the installation and as a punch-list item, if required, is the Purchaser's responsibility.

**Design**

All Products shown in the Seller's Price List and Specifications Guide are, and remain, the property of the Seller, who reserves the exclusive right to manufacture them. All dimensions shown are to be considered approximate. Seller reserves the right to make changes in price, dimensions, design and/or construction without prior notice.

**Shop Drawings**

Seller allows for one (1) set of full shop drawings and one (1) round of minor drawing revisions in its pricing and scheduling. Thereafter, any significant changes in design, including dimensions, engineering details, and materials, or delays in reviewing and approving shop drawings, may necessitate additional charges and cause schedule delays. Seller reserves the right to determine the impact of any design changes and/or delays and will promptly notify those involved of any adjustments to cost and schedule.

**Field and Hold Dimensions**

If a dealer or third party is responsible for providing installation, the following is required: Full responsibility for providing accurate and timely field dimensions or hold to dimensions (in cases where walls are not erected) as it effects the ultimate fit of the installation. As an alternative, upon request, Seller can provide a cost for sending a field technician to the project site to assume responsibility for field dimensions and site evaluation.

**Freight and Delivery**

Products are carefully inspected and packaged before leaving the factory to ensure they reach their destination in excellent condition. Whenever possible, the Seller will ship in accordance with the Purchaser's instructions. If Purchaser does not specify shipping instructions, Seller will use its best judgment to determine the most suitable shipping method, route, and carrier.

Conditions beyond the control of Seller, including weather, available facilities and traffic conditions, may affect time of delivery.

**Storage**

If the Purchaser cannot accept delivery per the ship date specified in the Seller's Acknowledgement, the Seller may transfer the merchandise to storage, either at its facility or at another facility.

Purchaser will be charged a storage fee of two percent (2%) of the invoice for every thirty (30) days the products are stored at the Seller's facility.

For products stored in another facility, all out-of-pocket costs of storage, including transportation and warehousing fees, will be at the Purchaser's expense.

The Purchaser will be invoiced for all product charges on the date the Products are transferred to storage. Storage fees will accrue monthly in full month increments (they are not pro-rated for partial months) and will be added to the first invoice, which will also include non-product charges such as shipping, installation, etc.

**Returns**

Purchasers may not return Products without Seller's written approval and shipping instructions. Unauthorized returns, and returns shipped inconsistently with Seller's instructions, will be automatically refused by the Seller's receiving department.

Products not currently offered for sale by Seller, including special and custom Products, shall not be authorized for return. All returned Products must be unused, in original condition and in original Seller shipping cartons. No refund or credit shall be given for damaged Products.

**Claims**

All shipments for Sellers Product are F.O.B. Origin. All risk of loss passes to Purchaser at time of delivery to carrier. Purchaser shall inspect all Products upon receipt and note any damage on the Bill of Lading and make an immediate request for inspection of damage by carrier. Seller is not responsible for damage that occurs in transit or storage.

Damage that becomes apparent after the Product is unpacked should be reported to the carrier and the Seller within twenty-four (24) hours of receipt. Damage that is incurred at a furniture dealer's warehouse is the responsibility of the furniture dealer.

For claims relating to Product damaged in transit, or for any other claims relating to or arising out of the transportation of the Product, Purchaser must seek recovery from the carrier. Seller may, upon request, assist Purchaser with filing of such claims with the carrier.

Claims for defects, errors, or shortages must be made in writing by Purchaser against Seller within 72 hours after delivery. Failure to make such claim within 72 hours shall constitute unconditional acceptance of the Products and a waiver of any apparent defects, errors, or shortages.

---

## Warranty

Seller warrants its Products to the original Purchaser to be free of defects in workmanship and materials under normal use and under conditions for which the Product was designed for a period of five years for custom product and 12 years for standard product. This remedy is exclusive. Seller does not authorize any person to create for it any obligation or liability.

During this warranty period, Seller will repair, or at its option, replace, such Product proven to be defective. Seller shall not be liable for commercial loss or any consequential or incidental damages that may arise as a result of defective Product.

This limited warranty does not apply to:

- Damage caused by a carrier other than the Seller.
- Product not properly maintained per Seller instructions. Maintenance and proper environmental conditions are described in Seller's Published Price List. All furniture should be used in a stable, controlled atmosphere and positioned to avoid direct sunlight. Ideal climate is 65 to 75 degrees Fahrenheit with 30 to 55% relative humidity.
- Normal wear and tear or acts or omissions of parties other than Seller. This warranty does not cover any product repaired or altered by any person not so authorized by Seller, including user modification, improper use or installation of Products.
- Customer's Own Material and Customer's Specified Laminates.
- Durability or suitability of any exterior surface coatings or treatments.
- Matching of color, grains or texture except as specified in the Seller's Order Confirmation and the finish sample.
- Natural variations occurring in wood, stone, and glass shall not be considered defects, and the Seller does not guarantee the colorfastness or matching of colors, grains or textures, or surface hardness of such materials.
- Adequacy of any electronic components.
- Durability of glass used in Product.
- Live Edge natural slabs used for table tops.

Seller must be notified within 72 hours of receipt of shipment for any initial claims for defects, errors or shortages.

To obtain the benefit of this warranty, contact Seller in writing. It is the responsibility of the Purchaser to arrange the return of Product to Seller and to assume all costs relating to any incidental or consequential damages.

## Disclaimers

THE EXPRESS WARRANTIES CONTAINED IN THIS SELLING POLICY ARE THE ONLY WARRANTIES THAT DATESWEISER MAKES AND TAKE THE PLACE OF ALL OTHER WARRANTIES, EXPRESS OR IMPLIED, INCLUDING ANY WARRANTIES OF MERCHANTABILITY OR FITNESS FOR PARTICULAR PURPOSE AND ALL OTHER WARRANTIES ARISING FROM COURSE OF DEALING OR USAGE OF TRADE.

Corporate Office / Factory

1700 Broadway Street

Buffalo, NY 14212

p 716.891.1700

# General Specifications

## Note:

Line drawings in this price list are purely for quick product identification without form of detail and cannot be used to satisfy production dimensions, shape or support options. Refer to Planning Guide for detailed product information.

## Wood Components

Tops are 1-1/4" or 2" thick.

Bases are constructed using 3/4" thick material with mitered corners, in two widths (3-1/2" and 6") and two depths (24-1/2" and 30-1/2"). Bases also have a hinged access door for wire management.

## Levelers

All bases are equipped with floor levelers to level the table.

## Grommets

Please contact customer service at [customerservice@datesweiser.com](mailto:customerservice@datesweiser.com) or your local DatesWeiser representative to request a quote based on your specific needs. To find your local representative, visit

[www.datesweiser.com/contacts](http://www.datesweiser.com/contacts).

## Power & Connectivity

Mounted discretely around the perimeter of the table, power & connectivity is available in two versions (Fixed and Slide-Out) in both plug-in and hardwire connections to accommodate almost any need you may have.

Wire management is easily handled vertically through the bases (via the hinged access door) and horizontally through the aprons.

Access door on 3-1/2" wide bases uses 3/4" finger-pull gap above the door to open.

Access door on 6" wide bases uses touch latch to open.

## Wood Finishes and Materials

Selecting materials and other features are the first steps to ordering your DatesWeiser furniture. As you move through the steps on the product pages, you will need to fill in the blanks with the codes for the finishes and features you select.

Wood veneers are selected from the finest hardwoods available around the world and top coated with a low-VOC, post-catalyzed finish. The typical sheen is 30%.

Veneers come in two price ranges (Tiers), and described as follows:

1. Cut (Plain-sliced, rift, quartered, engineered)
2. Species (Oak, Walnut, etc.)
3. Finish (Natural, Smoked, Dark, Cerused, etc.)

Quartered, rift-cut and engineered veneers are slip matched except for Black Limba.

Plain-sliced veneers are book matched.

Examples:

1. T124 (Denotes Tier 1 Plain sliced Maple, Natural)
2. T227 (Denotes Tier 2 Quartered Walnut, Natural)

## Paint Finishes and Materials

SL\_\_ (Satin Lacquer)

Opaque paint with a 50% typical sheen.

HG\_\_ (High Gloss Polyester) Opaque paint with a hand rubbed high gloss finish.

\*Color codes are entered in the blanks.

## Metal Finishes and Materials

MC\_\_ Powder Coat

A coating applied electrostatically as a dry powder, then cured under heat to allow it to flow and form a 9skin9. Used to create a hard finish that is more durable than conventional paint.

PM\_\_ Premium Metal Electroplating produces a premium metal finish.

\*Color codes entered in the blanks.

## Finishing Excellence

DatesWeiser collaborates with leading colorists to develop a palette particularly suited to the executive workplace. This range is available on all our products and coordinates with our extensive veneer offering.

To order finish samples, please contact customer service at [customerservice@datesweiser.com](mailto:customerservice@datesweiser.com) or your local DatesWeiser representative. To find your local DatesWeiser representative, visit

---

[www.datesweiser.com/contacts](http://www.datesweiser.com/contacts).

If you do not see what you want, we are happy to work with you to develop a unique product solution.

Datesweiser printed and veneer samples offer an example of what a typical veneer will look like, within a range of acceptability carefully determined by DatesWeiser. Samples and printed sample materials should be used as reference only.

**FSCT® Certification:****FSC®-C103565**

Responsibility harvested materials certified by the Forest Stewardship Council® (*FSC®-C103565*) are available upon request and may increase pricing. Requests for FSC® (*License: FSC®-C103565*) certified materials or LEED certification must be made before an order is processed.

**Product Maintenance**

Regular dusting with a soft cloth will help prevent fine dust particles from becoming embedded in the finished surface. We recommend using a soft flannel cloth slightly dampened with water, followed by a dry cloth. Always wipe in the direction of the grain.

**CAUTION:**

Never use a chemically treated cleaning cloth.

For removing residues, smudges, etc., we recommend using a very mild (non-ammonia) soap and water solution. Apply with a soft flannel cloth followed by a dry cloth. Always wipe in the direction of the grain.

We recommend using felt pads on all objects that come into contact with our furniture. Certain vinyl and rubber products can chemically react with the finish on wood if left in contact for extended periods of time. Coasters, place mats, notebook covers, and rubber or plastic feet (found on most accessories) can also damage wood surfaces. To avoid indentations caused by writing instruments, always use a non-vinyl blotter or writing pad.

All furniture should be used in a stable, controlled atmosphere and positioned to avoid direct sunlight. The ideal climate is 65-75°F with 30-55% relative humidity.

# Materials & Finish Pallete

---

## Veneer: Tier 1

**Applies to Tops & Bases**



**T102** Rift European White Oak, Natural



**T142** Rift American White Oak, Natural



**T105** Plain-sliced Walnut, Natural

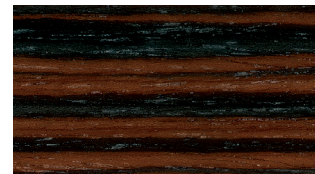

**T131** Reconstituted Macassar Ebony, Natural

## Veneer: Tier 2

**Applies to Tops & Bases**



**T206** Plain-sliced Walnut, Smoked

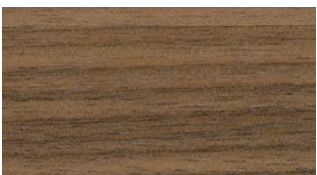

**T227** Quartered Walnut, Natural



**T228** Quartered Black Limba, Natural

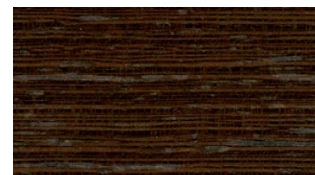

**T229** Quartered Wenge, Natural

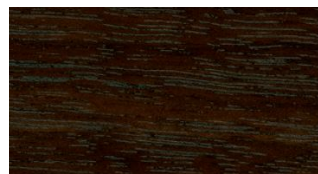

**T207** Plain-sliced Walnut, Dark

## Satin Lacquer

**Applies to Bases Only**

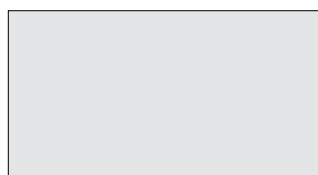

**SL01** White



**SL09** Black Brown



**HG13 / SL13** Jet Black



**HG08 / SL08** Umbra Grey





# JD Collection Conference Tables



**DATESWEISER**

# General Specifications

## Rectangular Conference Tables

### Edge Profiles

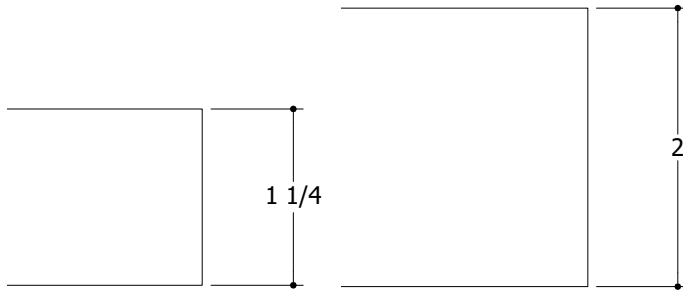

### Top Construction

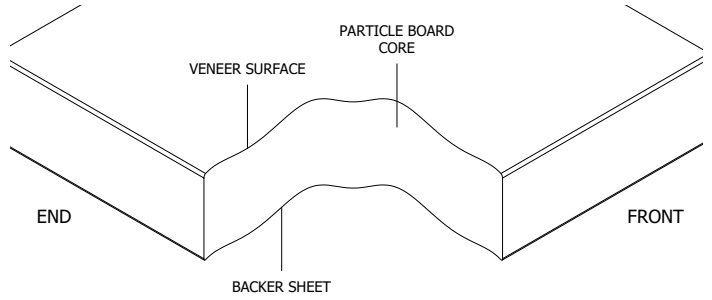

### Bases, 24-1/2" and 30-1/2" Deep with Magnetic Door

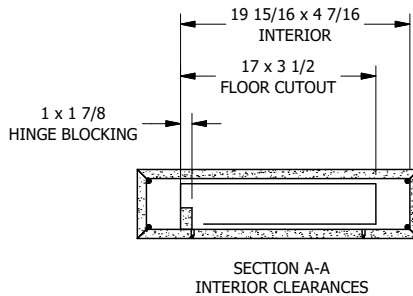
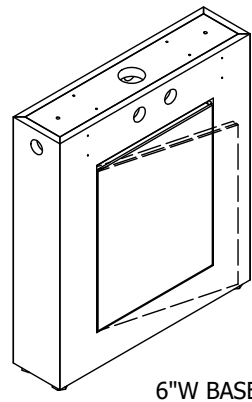
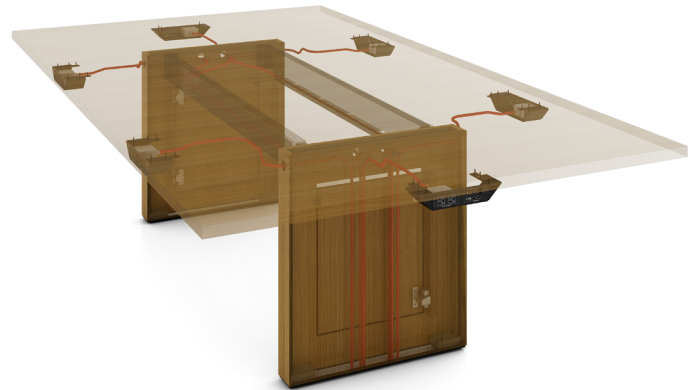
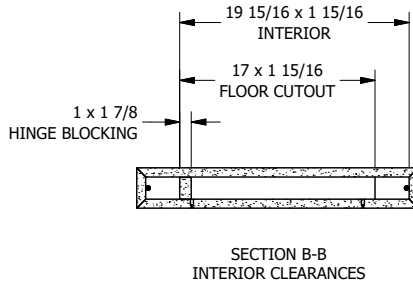
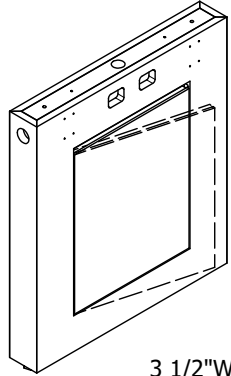

# General Specifications

## Rectangular Conference Tables

### Table Construction

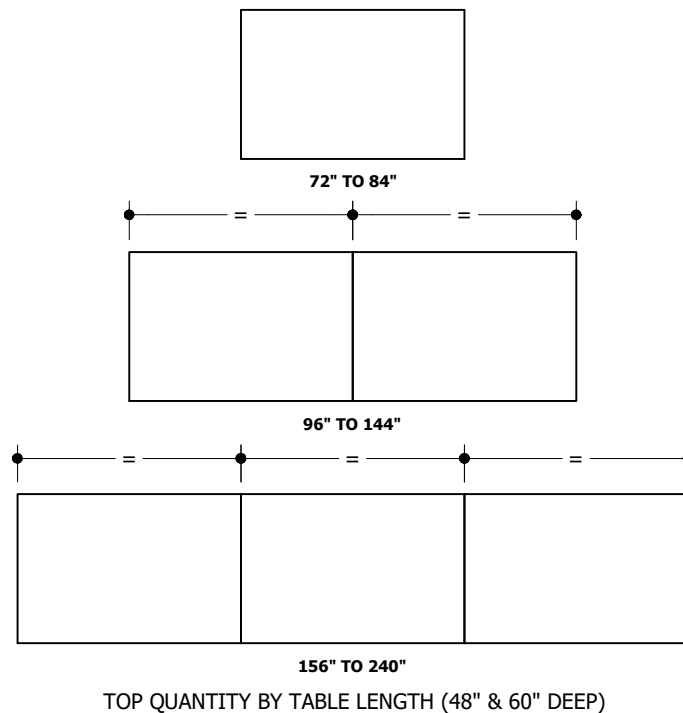
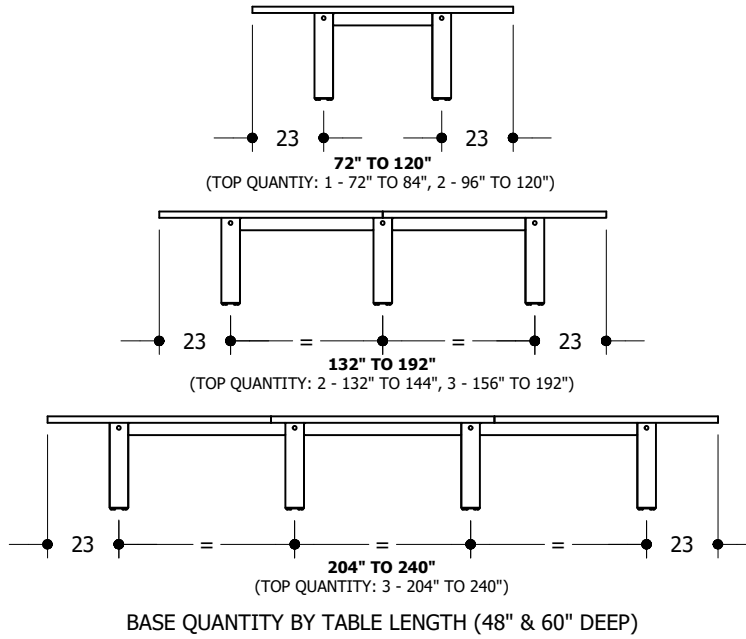

# General Specifications

## Rectangular Conference Tables

### Table Construction

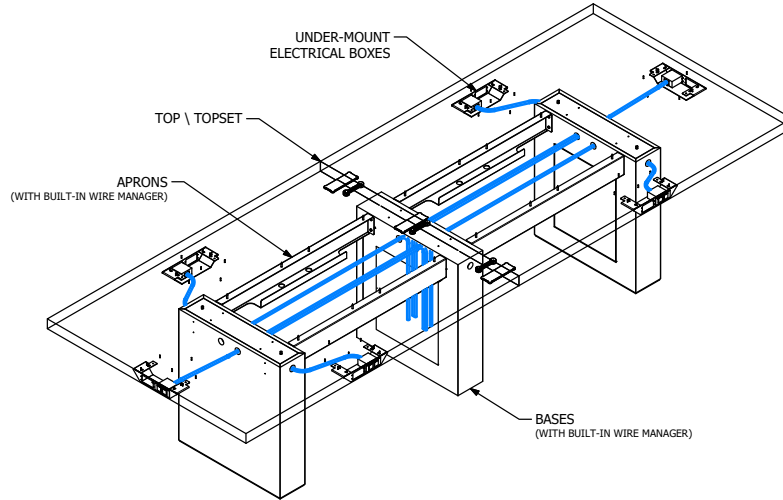

**WIRE MANAGEMENT ON TABLES WITH UNDER-MOUNT ELECTRICAL BOXES**

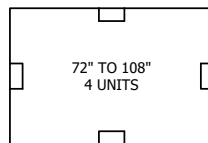
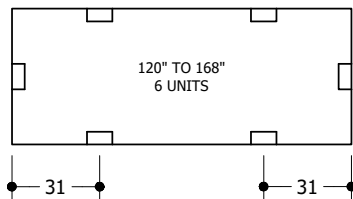
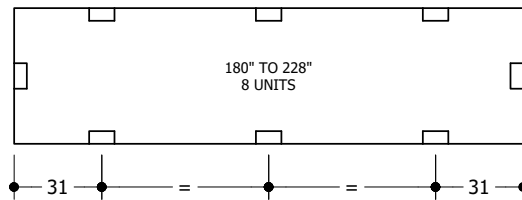
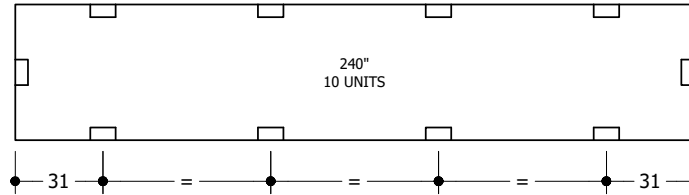

**POWER LOCATIONS & QUANTITY BY TABLE LENGTH**



# Rectangular Conference Tables

**48" Deep Tops, 29 1/4" High**  
**1 1/4" Thick Tops, 3 1/2" Wide Bases**

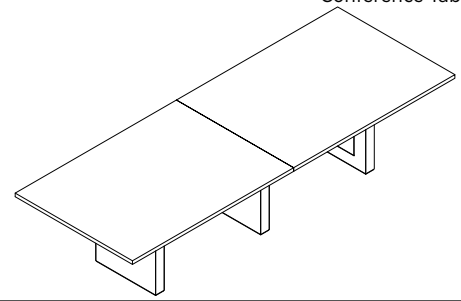

Type	D	W	H	Pattern No	T1P	T2P	T1 Upcharge	T2 Upcharge
1 (72") tops, 2 (3 1/2") bases	48"	72"	29 1/4"	<b>07R48X72V13</b>	\$7,992	\$8,337	\$890	\$1,243
1 (84") tops, 2 (3 1/2") bases	48"	84"	29 1/4"	<b>07R48X84V13</b>	8,490	8,891	890	1,243
2 (48") tops, 2 (3 1/2") bases	48"	96"	29 1/4"	<b>07R48X96V13</b>	8,961	9,420	890	1,243
2 (54") tops, 2 (3 1/2") bases	48"	108"	29 1/4"	<b>07R48X108V13</b>	9,516	10,043	890	1,243
2 (60") tops, 2 (3 1/2") bases	48"	120"	29 1/4"	<b>07R48X120V13</b>	9,991	10,567	890	1,243
2 (66") tops, 3 (3 1/2") bases	48"	132"	29 1/4"	<b>07R48X132V13</b>	12,316	12,955	1,337	1,864
2 (72") tops, 3 (3 1/2") bases	48"	144"	29 1/4"	<b>07R48X144V13</b>	12,831	13,521	1,337	1,864
3 (52") tops, 3 (3 1/2") bases	48"	156"	29 1/4"	<b>07R48X156V13</b>	13,323	14,069	1,337	1,864
3 (56") tops, 3 (3 1/2") bases	48"	168"	29 1/4"	<b>07R48X168V13</b>	13,818	14,621	1,337	1,864
3 (60") tops, 3 (3 1/2") bases	48"	180"	29 1/4"	<b>07R48X180V13</b>	14,314	15,178	1,337	1,864
3 (64") tops, 3 (3 1/2") bases	48"	192"	29 1/4"	<b>07R48X192V13</b>	15,226	16,158	1,337	1,864
3 (68") tops, 4 (3 1/2") bases	48"	204"	29 1/4"	<b>07R48X204V13</b>	17,170	18,139	1,782	2,484
3 (72") tops, 4 (3 1/2") bases	48"	216"	29 1/4"	<b>07R48X216V13</b>	17,655	18,698	1,782	2,484
3 (76") tops, 4 (3 1/2") bases	48"	228"	29 1/4"	<b>07R48X228V13</b>	18,163	19,243	1,782	2,484
3 (80") tops, 4 (3 1/2") bases	48"	240"	29 1/4"	<b>07R48X240V13</b>	18,651	19,805	1,782	2,484

Order Code	Specification Information	Pricing Tiers
Example: <b>07R48X72V13</b>	To order please specify pattern number including:	<b>T1P</b> = Tier 1 veneer top with painted base
<b>07</b> JD Collection		<b>T2P</b> = Tier 2 veneer top with painted bases
<b>R</b> Rect. Conf. Table	1. Top finish: ( )	<b>T1</b> = Upcharge from T1P for Tier 1 veneer bases
<b>48X</b> Depth	2. Base finish: ( )	<b>T2</b> = Upcharge from T2P for Tier 2 veneer bases
<b>72</b> Width	3. Power and connectivity (Optional, blank for none):	
<b>V</b> Veneer		
<b>1</b> 1 1/4" thick top	<b>UMHW</b> Under-mount, Hardwire	
<b>3</b> 3 1/2" wide base	<b>UMPI</b> Under-mount, Plug in <b>UMLK</b> Under-mount, Linkable	Please refer to Materials and Finishes <a href="#">page 7</a> for specification details. Please refer to Accessories <a href="#">page 81</a> for specification details.

### Application Notes

Tables ship knocked-down, assembly required.  
 Tables come with structural metal aprons, finished in metallic black powder (MC12).  
 Wire management handled vertically through bases and horizontally through aprons.  
 Bases can fully or partially conceal a floor core, pending the application. This ability will vary based on type, size, location of the floor core.

Finish and grain matched on tables with multi-piece tops  
 Undermount power units finished in metallic black powder (MC12).  
 Tops pre-drilled for installation of undermount power.  
 Undermount power unit comes with (x1) dual AC hardwire (HW) or plug in(PI) power module and (x2) single space blank plates.  
 For additional connectivity please contact sales person.

# Rectangular Conference Tables

**48" Deep Tops, 29 1/4" High**  
**1 1/4" Thick Tops, 6" Wide Bases**

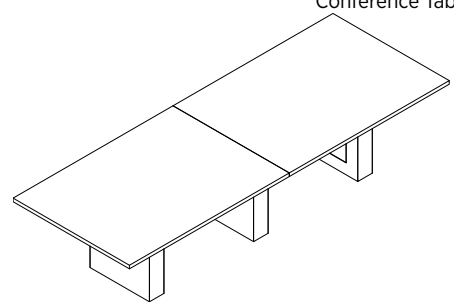

Type	D	W	H	Pattern No	T1P	T2P	T1 Upcharge	T2 Upcharge
1 (72") tops, 2 (6") bases	48"	72"	29 1/4"	<b>07R48X72V16</b>	\$8,110	\$8,466	\$890	\$1,243
1 (84") tops, 2 (6") bases	48"	84"	29 1/4"	<b>07R48X84V16</b>	8,620	9,022	890	1,243
2 (48") tops, 2 (6") bases	48"	96"	29 1/4"	<b>07R48X96V16</b>	9,115	9,573	890	1,243
2 (54") tops, 2 (6") bases	48"	108"	29 1/4"	<b>07R48X108V16</b>	9,613	10,133	890	1,243
2 (60") tops, 2 (6") bases	48"	120"	29 1/4"	<b>07R48X120V16</b>	10,119	10,686	890	1,243
2 (66") tops, 3 (6") bases	48"	132"	29 1/4"	<b>07R48X132V16</b>	12,521	13,170	1,337	1,864
2 (72") tops, 3 (6") bases	48"	144"	29 1/4"	<b>07R48X144V16</b>	13,017	13,707	1,337	1,864
3 (52") tops, 3 (6") bases	48"	156"	29 1/4"	<b>07R48X156V16</b>	13,527	14,272	1,337	1,864
3 (56") tops, 3 (6") bases	48"	168"	29 1/4"	<b>07R48X168V16</b>	14,018	14,839	1,337	1,864
3 (60") tops, 3 (6") bases	48"	180"	29 1/4"	<b>07R48X180V16</b>	14,524	15,380	1,337	1,864
3 (64") tops, 3 (6") bases	48"	192"	29 1/4"	<b>07R48X192V16</b>	15,423	16,357	1,337	1,864
3 (68") tops, 4 (6") bases	48"	204"	29 1/4"	<b>07R48X204V16</b>	17,433	18,403	1,782	2,484
3 (72") tops, 4 (6") bases	48"	216"	29 1/4"	<b>07R48X216V16</b>	17,915	18,962	1,782	2,484
3 (76") tops, 4 (6") bases	48"	228"	29 1/4"	<b>07R48X228V16</b>	18,426	19,519	1,782	2,484
3 (80") tops, 4 (6") bases	48"	240"	29 1/4"	<b>07R48X240V16</b>	18,923	20,083	1,782	2,484

Order Code	Specification Information	Pricing Tiers
Example: <b>07R48X72V16</b>	To order please specify pattern number including:	<b>T1P</b> = Tier 1 veneer top with painted base
<b>07</b> JD Collection		<b>T2P</b> = Tier 2 veneer top with painted bases
<b>R</b> Rect. Conf. Table	1. Top finish: ( )	<b>T1</b> = Upcharge from T1P for Tier 1 veneer bases
<b>48X</b> Depth	2. Base finish: ( )	<b>T2</b> = Upcharge from T2P for Tier 2 veneer bases
<b>72</b> Width	3. Power and connectivity (Optional, blank for none):	
<b>V</b> Veneer		
<b>1</b> 1 1/4" thick top	<b>UMHW</b> Under-mount, Hardwire	
<b>6</b> 6" wide base	<b>UMPI</b> Under-mount, Plug in <b>UMLK</b> Under-mount, Linkable	

Please refer to Materials and Finishes [page 7](#) for specification details. Please refer to Accessories [page 81](#) for specification details.

## Application Notes

Tables ship knocked-down, assembly required.  
 Tables come with structural metal aprons, finished in metallic black powder (MC12).  
 Wire management handled vertically through bases and horizontally through aprons.  
 Bases can fully or partially conceal a floor core, pending the application. This ability will vary based on type, size, location of the floor core.

Finish and grain matched on tables with multi-piece tops  
 Undermount power units finished in metallic black powder (MC12).  
 Tops pre-drilled for installation of undermount power.  
 Undermount power unit comes with (x1) dual AC hardwire (HW) or plug in (PI) power module and (x2) single space blank plates.  
 For additional connectivity please contact sales person.

# Rectangular Conference Tables

**48" Deep Tops, 29 1/4" High**

**2" Thick Tops, 3 1/2" Wide Bases**

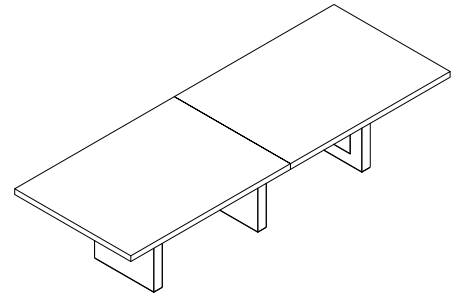

Type	D	W	H	Pattern No	T1P	T2P	T1 Upcharge	T2 Upcharge
1 (72") tops, 2 (3 1/2") bases	48"	72"	29 1/4"	<b>07R48X72V23</b>	\$8,284	\$8,629	\$890	\$1,243
1 (84") tops, 2 (3 1/2") bases	48"	84"	29 1/4"	<b>07R48X84V23</b>	8,825	9,230	890	1,243
2 (48") tops, 2 (3 1/2") bases	48"	96"	29 1/4"	<b>07R48X96V23</b>	9,355	9,815	890	1,243
2 (54") tops, 2 (3 1/2") bases	48"	108"	29 1/4"	<b>07R48X108V23</b>	9,959	10,485	890	1,243
2 (60") tops, 2 (3 1/2") bases	48"	120"	29 1/4"	<b>07R48X120V23</b>	10,470	11,050	890	1,243
2 (66") tops, 3 (3 1/2") bases	48"	132"	29 1/4"	<b>07R48X132V23</b>	12,862	13,503	1,337	1,864
2 (72") tops, 3 (3 1/2") bases	48"	144"	29 1/4"	<b>07R48X144V23</b>	13,406	14,111	1,337	1,864
3 (52") tops, 3 (3 1/2") bases	48"	156"	29 1/4"	<b>07R48X156V23</b>	13,960	14,716	1,337	1,864
3 (56") tops, 3 (3 1/2") bases	48"	168"	29 1/4"	<b>07R48X168V23</b>	14,513	15,307	1,337	1,864
3 (60") tops, 3 (3 1/2") bases	48"	180"	29 1/4"	<b>07R48X180V23</b>	15,074	15,916	1,337	1,864
3 (64") tops, 3 (3 1/2") bases	48"	192"	29 1/4"	<b>07R48X192V23</b>	16,017	16,944	1,337	1,864
3 (68") tops, 4 (3 1/2") bases	48"	204"	29 1/4"	<b>07R48X204V23</b>	18,002	18,988	1,782	2,484
3 (72") tops, 4 (3 1/2") bases	48"	216"	29 1/4"	<b>07R48X216V23</b>	18,548	19,263	1,782	2,484
3 (76") tops, 4 (3 1/2") bases	48"	228"	29 1/4"	<b>07R48X228V23</b>	19,102	19,867	1,782	2,484
3 (80") tops, 4 (3 1/2") bases	48"	240"	29 1/4"	<b>07R48X240V23</b>	19,650	20,463	1,782	2,484

Order Code	Specification Information	Pricing Tiers
Example: <b>07R48X72V23</b>	To order please specify pattern number including:	<b>T1P</b> = Tier 1 veneer top with painted base
<b>07</b> JD Collection		<b>T2P</b> = Tier 2 veneer top with painted bases
<b>R</b> Rect. Conf. Table	1. Top finish: ( )	<b>T1</b> = Upcharge from T1P for Tier 1 veneer bases
<b>48X</b> Depth	2. Base finish: ( )	<b>T2</b> = Upcharge from T2P for Tier 2 veneer bases
<b>72</b> Width	3. Power and connectivity (Optional, blank for none):	
<b>V</b> Veneer		
<b>2</b> 2" thick top	<b>UMHW</b> Under-mount, Hardwire	
<b>3</b> 3 1/2" wide base	<b>UMPI</b> Under-mount, Plug in <b>UMLK</b> Under-mount, Linkable	

Please refer to Materials and Finishes [page 7](#) for specification details. Please refer to Accessories [page 81](#) for specification details.

## Application Notes

Tables ship knocked-down, assembly required.  
 Tables come with structural metal aprons, finished in metallic black powder (MC12).  
 Wire management handled vertically through bases and horizontally through aprons.  
 Bases can fully or partially conceal a floor core, pending the application. This ability will vary based on type, size, location of the floor core.

Finish and grain matched on tables with multi-piece tops  
 Undermount power units finished in metallic black powder (MC12).  
 Tops pre-drilled for installation of undermount power.  
 Undermount power unit comes with (x1) dual AC hardwire (HW) or plug in (PI) power module and (x2) single space blank plates.  
 For additional connectivity please contact sales person.



# Rectangular Conference Tables

**48" Deep Tops, 29 1/4" High  
2" Thick Tops, 6" Wide Bases**

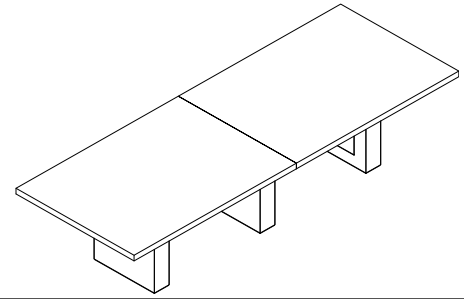

Type	D	W	H	Pattern No	T1P	T2P	T1 Upcharge	T2 Upcharge
1 (72") tops, 2 (6") bases	48"	72"	29 1/4"	<b>07R48X72V26</b>	\$8,408	\$8,753	\$890	\$1,243
1 (84") tops, 2 (6") bases	48"	84"	29 1/4"	<b>07R48X84V26</b>	8,958	9,372	890	1,243
2 (48") tops, 2 (6") bases	48"	96"	29 1/4"	<b>07R48X96V26</b>	9,515	9,978	890	1,243
2 (54") tops, 2 (6") bases	48"	108"	29 1/4"	<b>07R48X108V26</b>	10,063	10,569	890	1,243
2 (60") tops, 2 (6") bases	48"	120"	29 1/4"	<b>07R48X120V26</b>	10,612	11,179	890	1,243
2 (66") tops, 3 (6") bases	48"	132"	29 1/4"	<b>07R48X132V26</b>	13,062	13,696	1,337	1,864
2 (72") tops, 3 (6") bases	48"	144"	29 1/4"	<b>07R48X144V26</b>	13,622	14,299	1,337	1,864
3 (52") tops, 3 (6") bases	48"	156"	29 1/4"	<b>07R48X156V26</b>	14,155	14,913	1,337	1,864
3 (56") tops, 3 (6") bases	48"	168"	29 1/4"	<b>07R48X168V26</b>	14,709	15,518	1,337	1,864
3 (60") tops, 3 (6") bases	48"	180"	29 1/4"	<b>07R48X180V26</b>	15,259	16,117	1,337	1,864
3 (64") tops, 3 (6") bases	48"	192"	29 1/4"	<b>07R48X192V26</b>	17,434	17,149	1,337	1,864
3 (68") tops, 4 (6") bases	48"	204"	29 1/4"	<b>07R48X204V26</b>	18,274	19,236	1,782	2,484
3 (72") tops, 4 (6") bases	48"	216"	29 1/4"	<b>07R48X216V26</b>	18,821	19,854	1,782	2,484
3 (76") tops, 4 (6") bases	48"	228"	29 1/4"	<b>07R48X228V26</b>	19,366	20,442	1,782	2,484
3 (80") tops, 4 (6") bases	48"	240"	29 1/4"	<b>07R48X240V26</b>	19,918	21,064	1,782	2,484

Order Code	Specification Information	Pricing Tiers
Example: <b>07R48X72V26</b>	To order please specify pattern number including:	<b>T1P</b> = Tier 1 veneer top with painted base
<b>07</b> JD Collection		<b>T2P</b> = Tier 2 veneer top with painted bases
<b>R</b> Rect. Conf. Table	1. Top finish: ( )	<b>T1</b> = Upcharge from T1P for Tier 1 veneer bases
<b>48X</b> Depth	2. Base finish: ( )	<b>T2</b> = Upcharge from T2P for Tier 2 veneer bases
<b>72</b> Width	3. Power and connectivity (Optional, blank for none):	
<b>V</b> Veneer		
<b>2</b> 2" thick top	<b>UMHW</b> Under-mount, Hardwire	
<b>6</b> 6" wide base	<b>UMPI</b> Under-mount, Plug in <b>UMLK</b> Under-mount, Linkable	

Please refer to Materials and Finishes [page 7](#) for specification details. Please refer to Accessories [page 81](#) for specification details.

### Application Notes

Tables ship knocked-down, assembly required.  
Tables come with structural metal aprons, finished in metallic black powder (MC12).  
Wire management handled vertically through bases and horizontally through aprons.  
Bases can fully or partially conceal a floor core, pending the application. This ability will vary based on type, size, location of the floor core.

Finish and grain matched on tables with multi-piece tops  
Undermount power units finished in metallic black powder (MC12).  
Tops pre-drilled for installation of undermount power.  
Undermount power unit comes with (x1) dual AC hardwire (HW) or plug in (PI) power module and (x2) single space blank plates.  
For additional connectivity please contact sales person.

# Rectangular Conference Tables

**60" Deep Tops, 29 1/4" High**  
**1 1/4" Thick Tops, 3 1/2" Wide Bases**

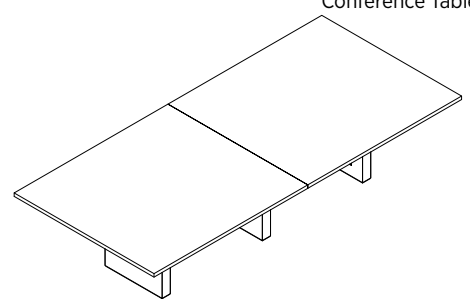

Type	D	W	H	Pattern No	T1P	T2P	T1 Upcharge	T2 Upcharge
1 (72") tops, 2 (3 1/2") bases	60"	72"	29 1/4"	<b>07R60X72V13</b>	\$8,715	\$9,149	\$911	\$1,267
1 (84") tops, 2 (3 1/2") bases	60"	84"	29 1/4"	<b>07R60X84V13</b>	9,332	9,849	911	1,267
2 (48") tops, 2 (3 1/2") bases	60"	96"	29 1/4"	<b>07R60X96V13</b>	9,957	10,534	911	1,267
2 (54") tops, 2 (3 1/2") bases	60"	108"	29 1/4"	<b>07R60X108V13</b>	10,573	11,222	911	1,267
2 (60") tops, 2 (3 1/2") bases	60"	120"	29 1/4"	<b>07R60X120V13</b>	11,190	11,923	911	1,267
2 (66") tops, 3 (3 1/2") bases	60"	132"	29 1/4"	<b>07R60X132V13</b>	13,664	14,452	1,380	1,913
2 (72") tops, 3 (3 1/2") bases	60"	144"	29 1/4"	<b>07R60X144V13</b>	14,272	15,144	1,380	1,913
3 (52") tops, 3 (3 1/2") bases	60"	156"	29 1/4"	<b>07R60X156V13</b>	14,890	15,820	1,380	1,913
3 (56") tops, 3 (3 1/2") bases	60"	168"	29 1/4"	<b>07R60X168V13</b>	15,518	16,518	1,380	1,913
3 (60") tops, 3 (3 1/2") bases	60"	180"	29 1/4"	<b>07R60X180V13</b>	16,129	17,219	1,380	1,913
3 (64") tops, 3 (3 1/2") bases	60"	192"	29 1/4"	<b>07R60X192V13</b>	17,167	18,305	1,380	1,913
3 (68") tops, 4 (3 1/2") bases	60"	204"	29 1/4"	<b>07R60X204V13</b>	19,223	20,437	1,820	2,534
3 (72") tops, 4 (3 1/2") bases	60"	216"	29 1/4"	<b>07R60X216V13</b>	19,819	21,122	1,820	2,534
3 (76") tops, 4 (3 1/2") bases	60"	228"	29 1/4"	<b>07R60X228V13</b>	20,204	21,569	1,820	2,534
3 (80") tops, 4 (3 1/2") bases	60"	240"	29 1/4"	<b>07R60X240V13</b>	21,052	22,508	1,820	2,534

Order Code	Specification Information	Pricing Tiers
Example: <b>07R60X72V13</b>	To order please specify pattern number including:	<b>T1P</b> = Tier 1 veneer top with painted base
<b>07</b> JD Collection		<b>T2P</b> = Tier 2 veneer top with painted bases
<b>R</b> Rect. Conf. Table	1. Top finish: ( )	<b>T1</b> = Upcharge from T1P for Tier 1 veneer bases
<b>60X</b> Depth	2. Base finish: ( )	<b>T2</b> = Upcharge from T2P for Tier 2 veneer bases
<b>72</b> Width	3. Power and connectivity (Optional, blank for none):	
<b>V</b> Veneer		
<b>1</b> 1 1/4" thick top	<b>UMHW</b> Under-mount, Hardwire	
<b>3</b> 3 1/2" wide base	<b>UMPI</b> Under-mount, Plug in <b>UMLK</b> Under-mount, Linkable	

Please refer to Materials and Finishes [page 7](#) for specification details. Please refer to Accessories [page 81](#) for specification details.

### Application Notes

Tables ship knocked-down, assembly required.  
 Tables come with structural metal aprons, finished in metallic black powder (MC12).  
 Wire management handled vertically through bases and horizontally through aprons.  
 Bases can fully or partially conceal a floor core, pending the application. This ability will vary based on type, size, location of the floor core.

Finish and grain matched on tables with multi-piece tops  
 Undermount power units finished in metallic black powder (MC12).  
 Tops pre-drilled for installation of undermount power.  
 Undermount power unit comes with (x1) dual AC hardwire (HW) or plug in (PI) power module and (x2) single space blank plates.  
 For additional connectivity please contact sales person.

# Rectangular Conference Tables

**60" Deep Tops, 29 1/4" High**  
**1 1/4" Thick Tops, 6" Wide Bases**

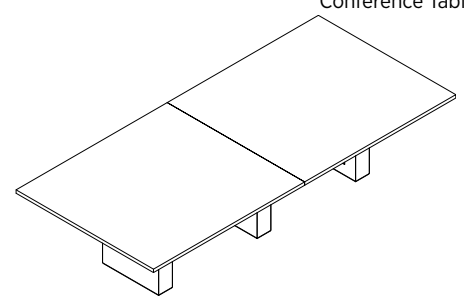

Type	D	W	H	Pattern No	T1P	T2P	T1 Upcharge	T2 Upcharge
1 (72") tops, 2 (6") bases	60"	72"	29 1/4"	<b>07R60X72V16</b>	\$8,784	\$9,211	\$911	\$1,267
1 (84") tops, 2 (6") bases	60"	84"	29 1/4"	<b>07R60X84V16</b>	9,390	9,900	911	1,267
2 (48") tops, 2 (6") bases	60"	96"	29 1/4"	<b>07R60X96V16</b>	10,007	10,585	911	1,267
2 (54") tops, 2 (6") bases	60"	108"	29 1/4"	<b>07R60X108V16</b>	10,634	11,284	911	1,267
2 (60") tops, 2 (6") bases	60"	120"	29 1/4"	<b>07R60X120V16</b>	11,257	11,975	911	1,267
2 (66") tops, 3 (6") bases	60"	132"	29 1/4"	<b>07R60X132V16</b>	13,745	14,523	1,380	1,913
2 (72") tops, 3 (6") bases	60"	144"	29 1/4"	<b>07R60X144V16</b>	14,360	15,231	1,380	1,913
3 (52") tops, 3 (6") bases	60"	156"	29 1/4"	<b>07R60X156V16</b>	14,985	15,907	1,380	1,913
3 (56") tops, 3 (6") bases	60"	168"	29 1/4"	<b>07R60X168V16</b>	15,591	16,590	1,380	1,913
3 (60") tops, 3 (6") bases	60"	180"	29 1/4"	<b>07R60X180V16</b>	16,220	17,289	1,380	1,913
3 (64") tops, 3 (6") bases	60"	192"	29 1/4"	<b>07R60X192V16</b>	17,242	18,394	1,380	1,913
3 (68") tops, 4 (6") bases	60"	204"	29 1/4"	<b>07R60X204V16</b>	19,317	20,531	1,820	2,534
3 (72") tops, 4 (6") bases	60"	216"	29 1/4"	<b>07R60X216V16</b>	19,945	21,220	1,820	2,534
3 (76") tops, 4 (6") bases	60"	228"	29 1/4"	<b>07R60X228V16</b>	20,329	21,696	1,820	2,534
3 (80") tops, 4 (6") bases	60"	240"	29 1/4"	<b>07R60X240V16</b>	21,182	22,610	1,820	2,534

Order Code	Specification Information	Pricing Tiers
Example: <b>07R60X72V16</b>	To order please specify pattern number including:	<b>T1P</b> = Tier 1 veneer top with painted base
<b>07</b> JD Collection		<b>T2P</b> = Tier 2 veneer top with painted bases
<b>R</b> Rect. Conf. Table	1. Top finish: ( )	<b>T1</b> = Upcharge from T1P for Tier 1 veneer bases
<b>60X</b> Depth	2. Base finish: ( )	<b>T2</b> = Upcharge from T2P for Tier 2 veneer bases
<b>72</b> Width	3. Power and connectivity (Optional, blank for none):	
<b>V</b> Veneer		
<b>1</b> 1 1/4" thick top	<b>UMHW</b> Under-mount, Hardwire	
<b>6</b> 6" wide base	<b>UMPI</b> Under-mount, Plug in <b>UMLK</b> Under-mount, Linkable	

Please refer to Materials and Finishes [page 7](#) for specification details. Please refer to Accessories [page 81](#) for specification details.

### Application Notes

Tables ship knocked-down, assembly required.  
 Tables come with structural metal aprons, finished in metallic black powder (MC12).  
 Wire management handled vertically through bases and horizontally through aprons.  
 Bases can fully or partially conceal a floor core, pending the application. This ability will vary based on type, size, location of the floor core.

Finish and grain matched on tables with multi-piece tops  
 Undermount power units finished in metallic black powder (MC12).  
 Tops pre-drilled for installation of undermount power.  
 Undermount power unit comes with (x1) dual AC hardwire (HW) or plug in (PI) power module and (x2) single space blank plates.  
 For additional connectivity please contact sales person.

# Rectangular Conference Tables

**60" Deep Tops, 29 1/4" High**

**2" Thick Tops, 3 1/2" Wide Bases**

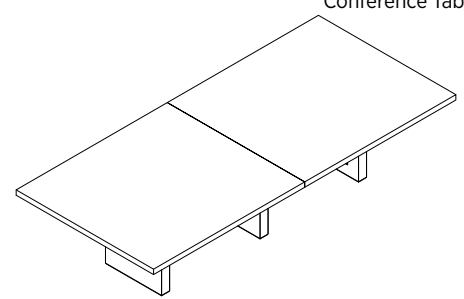

Type	D	W	H	Pattern No	T1P	T2P	T1 Upcharge	T2 Upcharge
1 (72") tops, 2 (3 1/2") bases	60"	72"	29 1/4"	<b>07R60X72V23</b>	\$9,095	\$9,527	\$911	\$1,267
1 (84") tops, 2 (3 1/2") bases	60"	84"	29 1/4"	<b>07R60X84V23</b>	9,765	10,266	911	1,267
2 (48") tops, 2 (3 1/2") bases	60"	96"	29 1/4"	<b>07R60X96V23</b>	10,444	11,036	911	1,267
2 (54") tops, 2 (3 1/2") bases	60"	108"	29 1/4"	<b>07R60X108V23</b>	11,136	11,776	911	1,267
2 (60") tops, 2 (3 1/2") bases	60"	120"	29 1/4"	<b>07R60X120V23</b>	11,816	12,524	911	1,267
2 (66") tops, 3 (3 1/2") bases	60"	132"	29 1/4"	<b>07R60X132V23</b>	14,340	15,123	1,380	1,913
2 (72") tops, 3 (3 1/2") bases	60"	144"	29 1/4"	<b>07R60X144V23</b>	15,017	15,888	1,380	1,913
3 (52") tops, 3 (3 1/2") bases	60"	156"	29 1/4"	<b>07R60X156V23</b>	15,682	16,640	1,380	1,913
3 (56") tops, 3 (3 1/2") bases	60"	168"	29 1/4"	<b>07R60X168V23</b>	16,362	17,371	1,380	1,913
3 (60") tops, 3 (3 1/2") bases	60"	180"	29 1/4"	<b>07R60X180V23</b>	17,050	18,151	1,380	1,913
3 (64") tops, 3 (3 1/2") bases	60"	192"	29 1/4"	<b>07R60X192V23</b>	18,132	19,308	1,380	1,913
3 (68") tops, 4 (3 1/2") bases	60"	204"	29 1/4"	<b>07R60X204V23</b>	20,248	21,483	1,820	2,534
3 (72") tops, 4 (3 1/2") bases	60"	216"	29 1/4"	<b>07R60X216V23</b>	20,921	22,220	1,820	2,534
3 (76") tops, 4 (3 1/2") bases	60"	228"	29 1/4"	<b>07R60X228V23</b>	21,388	22,741	1,820	2,534
3 (80") tops, 4 (3 1/2") bases	60"	240"	29 1/4"	<b>07R60X240V23</b>	22,300	23,734	1,820	2,534

Order Code	Specification Information	Pricing Tiers
Example: <b>07R60X72V23</b>	To order please specify pattern number including:	<b>T1P</b> = Tier 1 veneer top with painted base
<b>07</b> JD Collection		<b>T2P</b> = Tier 2 veneer top with painted bases
<b>R</b> Rect. Conf. Table	1. Top finish: ( )	<b>T1</b> = Upcharge from T1P for Tier 1 veneer bases
<b>60X</b> Depth	2. Base finish: ( )	<b>T2</b> = Upcharge from T2P for Tier 2 veneer bases
<b>72</b> Width	3. Power and connectivity (Optional, blank for none):	
<b>V</b> Veneer		
<b>2</b> 2" thick top	<b>UMHW</b> Under-mount, Hardwire	
<b>3</b> 3 1/2" wide base	<b>UMPI</b> Under-mount, Plug in <b>UMLK</b> Under-mount, Linkable	

### Application Notes

Tables ship knocked-down, assembly required.  
 Tables come with structural metal aprons, finished in metallic black powder (MC12).  
 Wire management handled vertically through bases and horizontally through aprons.  
 Bases can fully or partially conceal a floor core, pending the application. This ability will vary based on type, size, location of the floor core.

Finish and grain matched on tables with multi-piece tops  
 Undermount power units finished in metallic black powder (MC12).  
 Tops pre-drilled for installation of undermount power.  
 Undermount power unit comes with (x1) dual AC hardwire (HW) or plug in (PI) power module and (x2) single space blank plates.  
 For additional connectivity please contact sales person.

# Rectangular Conference Tables

**60" Deep Tops, 29 1/4" High**

**2" Thick Tops, 6" Wide Bases**

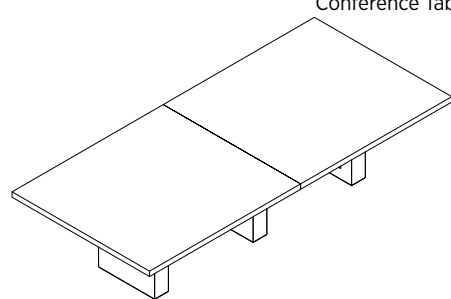

Type	D	W	H	Pattern No	T1P	T2P	T1 Upcharge	T2 Upcharge
1 (72") tops, 2 (6") bases	60"	72"	29 1/4"	<b>07R60X72V26</b>	\$9,227	\$9,648	\$911	\$1,267
1 (84") tops, 2 (6") bases	60"	84"	29 1/4"	<b>07R60X84V26</b>	9,908	10,404	911	1,267
2 (48") tops, 2 (6") bases	60"	96"	29 1/4"	<b>07R60X96V26</b>	10,587	11,159	911	1,267
2 (54") tops, 2 (6") bases	60"	108"	29 1/4"	<b>07R60X108V26</b>	11,272	11,907	911	1,267
2 (60") tops, 2 (6") bases	60"	120"	29 1/4"	<b>07R60X120V26</b>	11,952	12,665	911	1,267
2 (66") tops, 3 (6") bases	60"	132"	29 1/4"	<b>07R60X132V26</b>	14,524	15,331	1,380	1,913
2 (72") tops, 3 (6") bases	60"	144"	29 1/4"	<b>07R60X144V26</b>	15,210	16,072	1,380	1,913
3 (52") tops, 3 (6") bases	60"	156"	29 1/4"	<b>07R60X156V26</b>	15,897	16,836	1,380	1,913
3 (56") tops, 3 (6") bases	60"	168"	29 1/4"	<b>07R60X168V26</b>	16,577	17,564	1,380	1,913
3 (60") tops, 3 (6") bases	60"	180"	29 1/4"	<b>07R60X180V26</b>	17,266	18,341	1,380	1,913
3 (64") tops, 3 (6") bases	60"	192"	29 1/4"	<b>07R60X192V26</b>	18,337	19,480	1,380	1,913
3 (68") tops, 4 (6") bases	60"	204"	29 1/4"	<b>07R60X204V26</b>	20,520	21,761	1,820	2,534
3 (72") tops, 4 (6") bases	60"	216"	29 1/4"	<b>07R60X216V26</b>	21,192	22,490	1,820	2,534
3 (76") tops, 4 (6") bases	60"	228"	29 1/4"	<b>07R60X228V26</b>	21,890	23,257	1,820	2,534
3 (80") tops, 4 (6") bases	60"	240"	29 1/4"	<b>07R60X240V26</b>	22,571	23,991	1,820	2,534

Order Code	Specification Information	Pricing Tiers
Example: <b>07R60X72V26</b>	To order please specify pattern number including:	<b>T1P</b> = Tier 1 veneer top with painted base
<b>07</b> JD Collection		<b>T2P</b> = Tier 2 veneer top with painted bases
<b>R</b> Rect. Conf. Table	1. Top finish: ( )	<b>T1</b> = Upcharge from T1P for Tier 1 veneer bases
<b>60X</b> Depth	2. Base finish: ( )	<b>T2</b> = Upcharge from T2P for Tier 2 veneer bases
<b>72</b> Width	3. Power and connectivity (Optional, blank for none):	
<b>V</b> Veneer		
<b>2</b> 2" thick top	<b>UMHW</b> Under-mount, Hardwire	
<b>6</b> 6" wide base	<b>UMPI</b> Under-mount, Plug in <b>UMLK</b> Under-mount, Linkable	

### Application Notes

Tables ship knocked-down, assembly required.  
 Tables come with structural metal aprons, finished in metallic black powder (MC12).  
 Wire management handled vertically through bases and horizontally through aprons.  
 Bases can fully or partially conceal a floor core, pending the application. This ability will vary based on type, size, location of the floor core.

Finish and grain matched on tables with multi-piece tops  
 Undermount power units finished in metallic black powder (MC12).  
 Tops pre-drilled for installation of undermount power.  
 Undermount power unit comes with (x1) dual AC hardwire (HW) or plug in (PI) power module and (x2) single space blank plates.  
 For additional connectivity please contact sales person.



# JD Collection

## Media Tables



**DATESWEISER**

# General Specifications

## Media Tables

### Edge Profiles

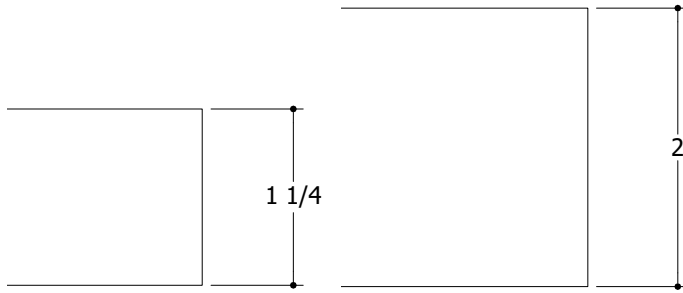

### Top Construction

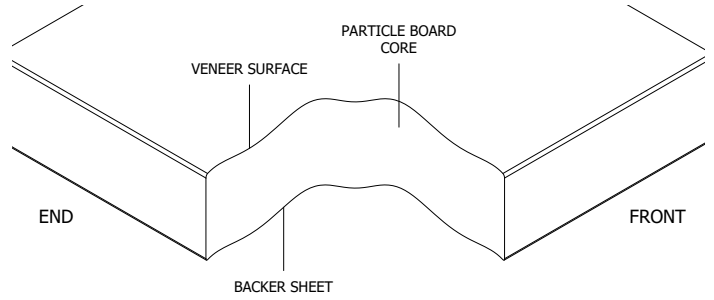

### Bases, 24-1/2" and 30-1/2" Deep with Magnetic Door

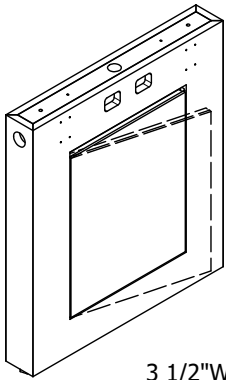

3 1/2"W BASE

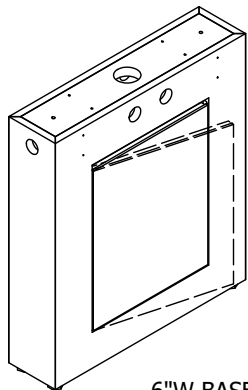
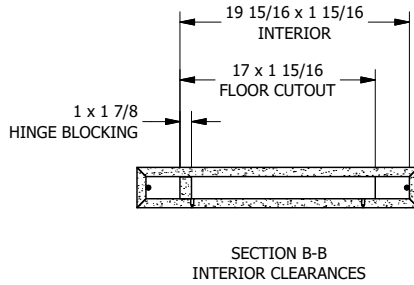

6"W BASE

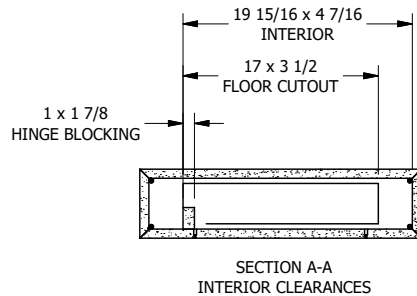



# General Specifications

## Media Tables

### Table Construction

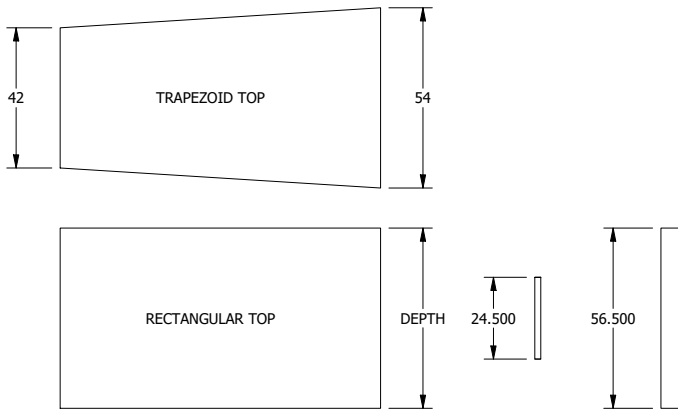

### Wall Mounted Table Construction (no Media Wall)

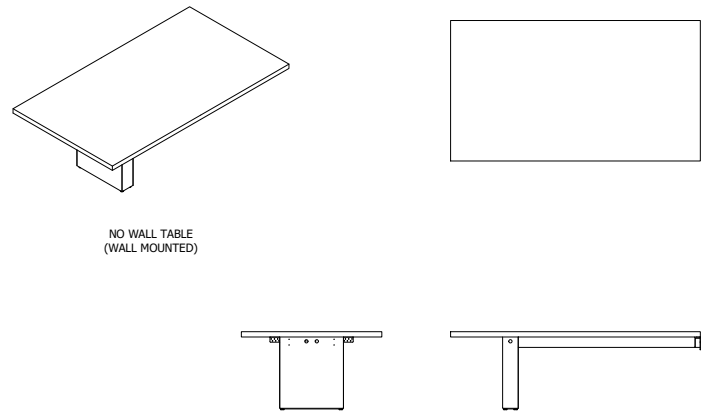

### Partial Media Wall Table Construction

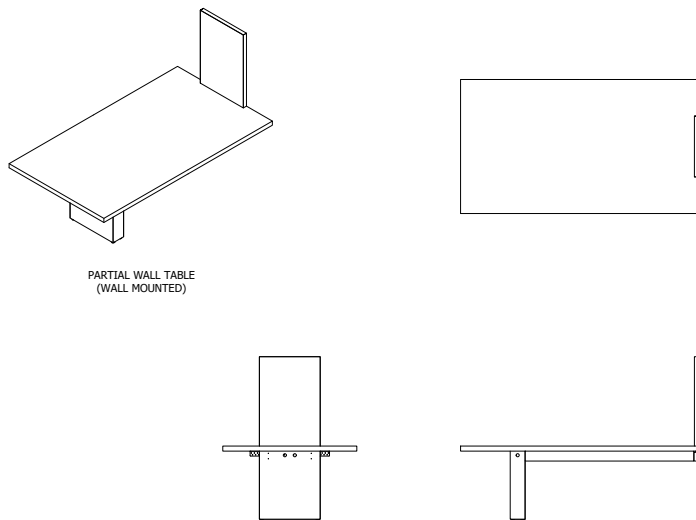

### Full Media Wall Table Construction

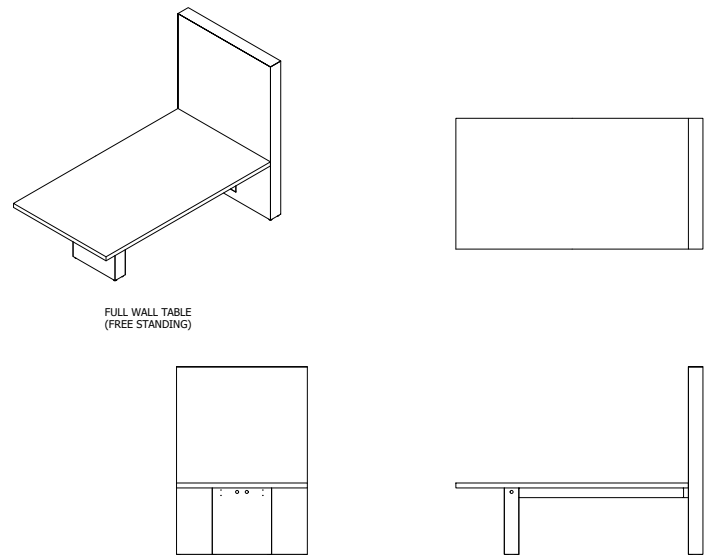

# General Specifications

## Media Tables

### Partial Wall Cable Planning

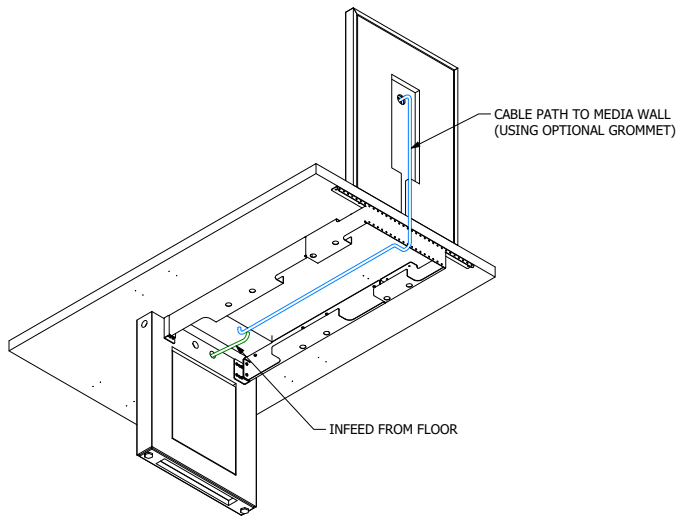

CABLING DIAGRAM:  
WALL-MOUNTED TABLE AND PARTIAL MEDIA WALL  
WITH TABLETOP POWER OPTION

### Under-mount Power Option

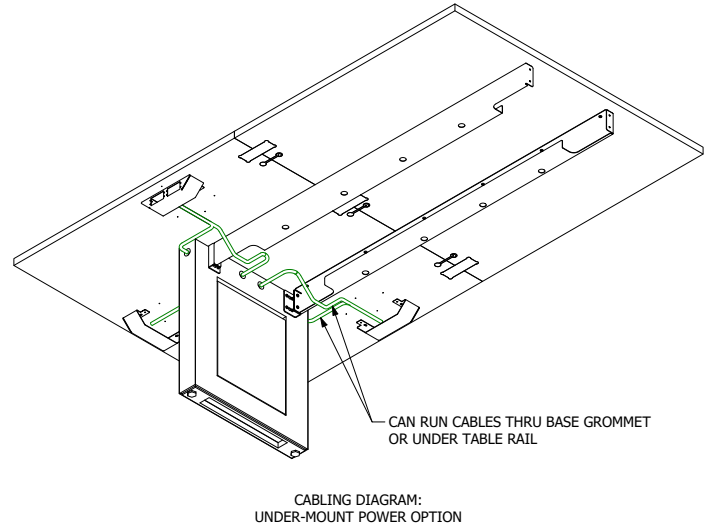

### Full-Height Media Wall, 59-9/16" Deep with Magnetic Door

### Partial Wall Cable Planning

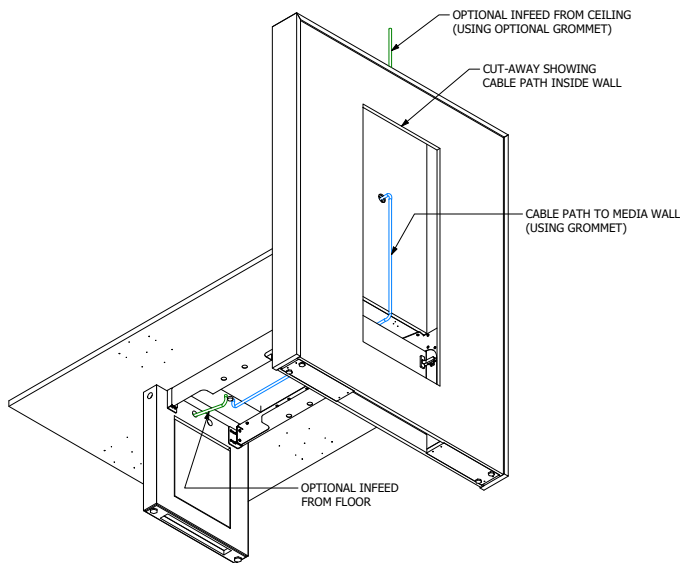

CABLING DIAGRAM:  
FREE-STANDING TABLE AND FULL MEDIA WALL  
WITH TABLETOP POWER OPTION

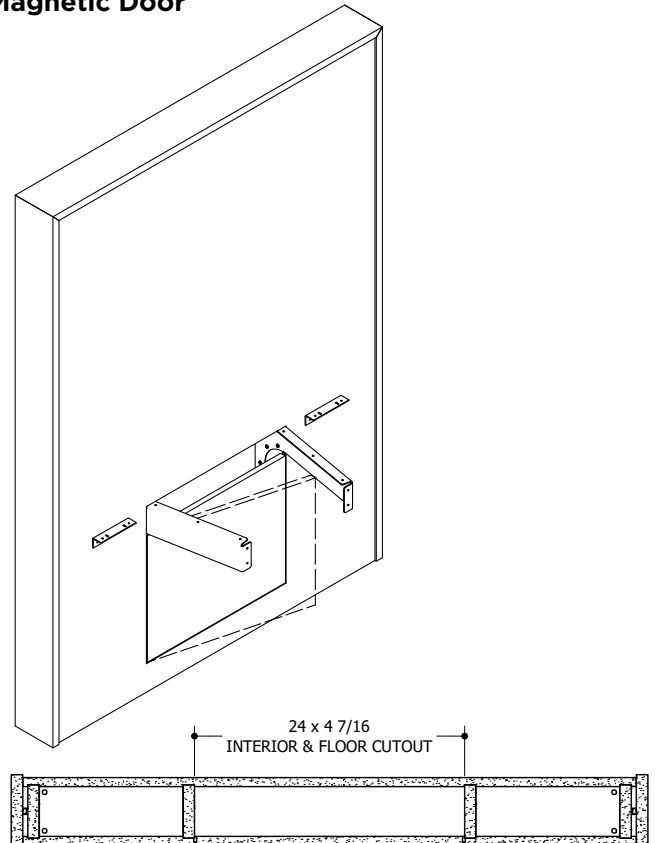



# Rectangular Media Tables

**42" Deep Tops**

**1 1/4" Thick Top, 3 1/2" Wide Bases**

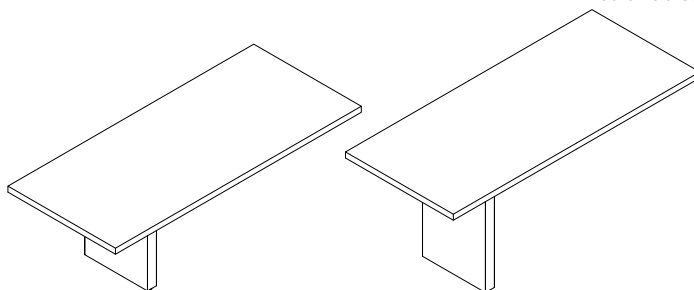

Type	D	W	H	Pattern No.	TP1	TP2	T1 Upcharge	T2 Upcharge
1 (60") top, 1 (3 1/2") Base	42"	60"	29 1/4"	<b>07MR42X60V1330</b>	\$5,931	\$6,215	\$448	\$628
1 (72") top, 1 (3 1/2") Base	42"	72"	29 1/4"	<b>07MR42X72V1330</b>	6,026	6,317	448	628
1 (84") top, 1 (3 1/2") Base	42"	84"	29 1/4"	<b>07MR42X84V1330</b>	6,047	6,339	448	628
2 (48") tops, 1 (3 1/2") Base	42"	96"	29 1/4"	<b>07MR42X96V1330</b>	6,143	6,443	448	628
1 (60") top, 1 (3 1/2") Base	42"	60"	40 1/2"	<b>07MR42X60V1342</b>	6,386	6,704	448	628
1 (72") top, 1 (3 1/2") Base	42"	72"	40 1/2"	<b>07MR42X72V1342</b>	6,479	6,807	448	628
1 (84") top, 1 (3 1/2") Base	42"	84"	40 1/2"	<b>07MR42X84V1342</b>	6,510	6,839	448	628
2 (48") tops, 1 (3 1/2") Base	42"	96"	40 1/2"	<b>07MR42X96V1342</b>	6,607	6,944	448	628

Order Code	Specification Information	Pricing Tiers
Example: <b>07MR42X60V1330</b>	To order please specify pattern number including:	<b>T1P</b> = Tier 1 veneer top with painted base
<b>07</b> JD Collection	1. Top finish: ( )	<b>T2P</b> = Tier 2 veneer top with painted bases
<b>MR</b> Media Table Rectangular	2. Base finish: ( )	<b>T1</b> = Upcharge from T1P for Tier 1 veneer bases
<b>42X</b> Depth	3. Power and connectivity (Optional, blank for none):	<b>T2</b> = Upcharge from T2P for Tier 2 veneer bases
<b>60</b> Width	<b>UMHW</b> Under-mount, Hardwire.	
<b>V</b> Veneer	<b>UMPI</b> Under-mount, Plug in.	
<b>1</b> 1 1/4" thick top	<b>UMLK</b> Under-mount, Linkable.	
<b>3</b> 3 1/2" wide base	<b>TSHW</b> Top-mount Small, Hardwired.	
<b>30</b> Height	<b>TSPI</b> Top-mount Small, Plug in.	
	<b>TLHW</b> Top-mount Large, Hardwired.	
	<b>TLPI</b> Top-mount Large, Plug in.	

Please refer to Materials and Finishes [page 7](#) for specification details. Please refer to Accessories [page 81](#) for specification details.

### Application Notes

Tables comes with only one base.  
 Under-mount and slide-out power is always Black.  
 Tables ship knocked-down, assembly required.  
 Tables come with structural metal aprons, finished in metallic black powder (MC12).  
 Wire management handled vertically through bases and horizontally through aprons.  
 Bases can fully or partially conceal a floor core, pending the application. This ability will vary based on type, size, location of the floor core.

Finish and grain matched on tables with multi-piece tops  
 Undermount power units finished in metallic black powder (MC12).  
 Tops pre-drilled for installation of undermount power.  
 Undermount power unit comes with (x1) dual AC hardwire (HW) or plug in(PI) power module and (x2) single space blank plates. For additional connectivity please contact sales person.  
 Top-mount power is available in 5 finishes:  
 Black = ECB  
 White = ECGW  
 Silver = ECS  
 Brushed Aluminum = ECAL  
 Stainless Steel = ECSS.

# Rectangular Media Tables

**42" Deep Tops**

**2" Thick Top, 3 1/2" Wide Bases**

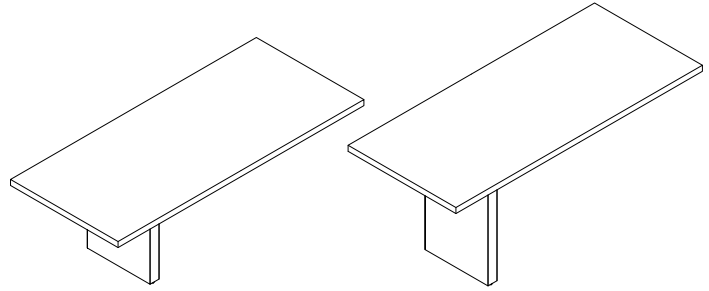

Type	D	W	H	Pattern No.	TP1	TP2	T1 Upcharge	T2 Upcharge
1 (60") top, 1 (3 1/2") Base	42"	60"	29 1/4"	<b>07MR42X60V2330</b>	\$6,080	\$6,375	\$448	\$628
1 (72") top, 1 (3 1/2") Base	42"	72"	29 1/4"	<b>07MR42X72V2330</b>	6,491	6,818	448	628
1 (84") top, 1 (3 1/2") Base	42"	84"	29 1/4"	<b>07MR42X84V2330</b>	6,198	6,502	448	628
2 (48") tops, 1 (3 1/2") Base	42"	96"	29 1/4"	<b>07MR42X96V2330</b>	6,618	6,956	448	628
1 (60") top, 1 (3 1/2") Base	42"	60"	40 1/2"	<b>07MR42X60V2342</b>	6,804	7,157	448	628
1 (72") top, 1 (3 1/2") Base	42"	72"	40 1/2"	<b>07MR42X72V2342</b>	6,946	7,310	448	628
1 (84") top, 1 (3 1/2") Base	42"	84"	40 1/2"	<b>07MR42X84V2342</b>	6,936	7,300	448	628
2 (48") tops, 1 (3 1/2") Base	42"	96"	40 1/2"	<b>07MR42X96V2342</b>	7,082	7,457	448	628

Order Code	Specification Information	Pricing Tiers
Example: <b>07MR42X60V2330</b>	To order please specify pattern number including:	<b>T1P</b> = Tier 1 veneer top with painted base
<b>07</b> JD Collection	1. Top finish: ( )	<b>T2P</b> = Tier 2 veneer top with painted bases
<b>MR</b> Media Table Rectangular	2. Base finish: ( )	<b>T1</b> = Upcharge from T1P for Tier 1 veneer bases
<b>42X</b> Depth	3. Power and connectivity (Optional, blank for none):	<b>T2</b> = Upcharge from T2P for Tier 2 veneer bases
<b>60</b> Width	<b>UMHW</b> Under-mount, Hardwire.	
<b>V</b> Veneer	<b>UMPI</b> Under-mount, Plug in.	
<b>2</b> 2" thick top	<b>UMLK</b> Under-mount, Linkable.	
<b>3</b> 3 1/2" wide base	<b>TSHW</b> Top-mount Small, Hardwired.	
<b>30</b> Height	<b>TSPI</b> Top-mount Small, Plug in.	
	<b>TLHW</b> Top-mount Large, Hardwired.	
	<b>TLPI</b> Top-mount Large, Plug in.	

Please refer to Materials and Finishes [page 7](#) for specification details. Please refer to Accessories [page 81](#) for specification details.

### Application Notes

Tables comes with only one base.  
 Under-mount and slide-out power is always Black.  
 Tables ship knocked-down, assembly required.  
 Tables come with structural metal aprons, finished in metallic black powder (MC12).  
 Wire management handled vertically through bases and horizontally through aprons.  
 Bases can fully or partially conceal a floor core, pending the application. This ability will vary based on type, size, location of the floor core.

Finish and grain matched on tables with multi-piece tops  
 Undermount power units finished in metallic black powder (MC12).  
 Tops pre-drilled for installation of undermount power.  
 Undermount power unit comes with (x1) dual AC hardwire (HW) or plug in(PI) power module and (x2) single space blank plates. For additional connectivity please contact sales person.  
 Top-mount power is available in 5 finishes:  
 Black = ECB  
 White = ECGW  
 Silver = ECS  
 Brushed Aluminum = ECAL  
 Stainless Steel = ECSS.

# Rectangular Media Tables

**42" Deep Tops**

**1 1/4" Thick Top, 6" Wide Bases**

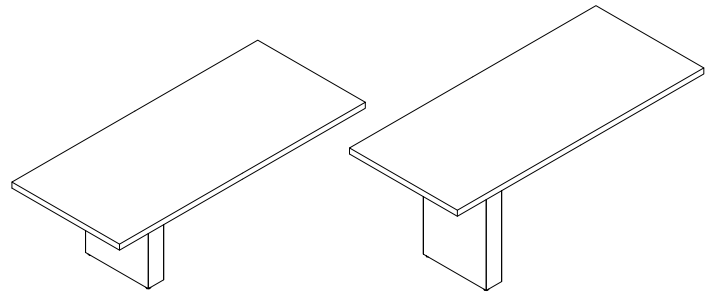

Type	D	W	H	Pattern No.	TP1	TP2	T1 Upcharge	T2 Upcharge
1 (60") top, 1 (6") Base	42"	60"	29 1/4"	<b>07MR42X60V1630</b>	\$6,840	\$7,196	\$448	\$628
1 (72") top, 1 (6") Base	42"	72"	29 1/4"	<b>07MR42X72V1630</b>	6,943	7,307	448	628
1 (84") top, 1 (6") Base	42"	84"	29 1/4"	<b>07MR42X84V1630</b>	6,975	7,340	448	628
2 (48") tops, 1 (6") Base	42"	96"	29 1/4"	<b>07MR42X96V1630</b>	7,078	7,453	448	628
1 (60") top, 1 (6") Base	42"	60"	40 1/2"	<b>07MR42X60V1642</b>	7,295	7,686	448	628
1 (72") top, 1 (6") Base	42"	72"	40 1/2"	<b>07MR42X72V1642</b>	7,394	7,794	448	628
1 (84") top, 1 (6") Base	42"	84"	40 1/2"	<b>07MR42X84V1642</b>	7,437	7,841	448	628
2 (48") tops, 1 (6") Base	42"	96"	40 1/2"	<b>07MR42X96V1642</b>	7,539	7,950	448	628

Order Code	Specification Information	Pricing Tiers
Example: <b>07MR42X60V1630</b>	To order please specify pattern number including:	<b>T1P</b> = Tier 1 veneer top with painted base
<b>07</b> JD Collection	1. Top finish: ( )	<b>T2P</b> = Tier 2 veneer top with painted bases
<b>MR</b> Media Table Rectangular	2. Base finish: ( )	<b>T1</b> = Upcharge from T1P for Tier 1 veneer bases
<b>42X</b> Depth	3. Power and connectivity (Optional, blank for none):	<b>T2</b> = Upcharge from T2P for Tier 2 veneer bases
<b>60</b> Width	<b>UMHW</b> Under-mount, Hardwire.	
<b>V</b> Veneer	<b>UMPI</b> Under-mount, Plug in.	
<b>1</b> 1 1/4" thick top	<b>UMLK</b> Under-mount, Linkable.	
<b>6</b> 6" wide base	<b>TSHW</b> Top-mount Small, Hardwired.	
<b>30</b> Height	<b>TSPI</b> Top-mount Small, Plug in.	
	<b>TLHW</b> Top-mount Large, Hardwired.	
	<b>TLPI</b> Top-mount Large, Plug in.	

Please refer to Materials and Finishes [page 7](#) for specification details. Please refer to Accessories [page 81](#) for specification details.

### Application Notes

Tables comes with only one base.  
 Under-mount and slide-out power is always Black.  
 Tables ship knocked-down, assembly required.  
 Tables come with structural metal aprons, finished in metallic black powder (MC12).  
 Wire management handled vertically through bases and horizontally through aprons.  
 Bases can fully or partially conceal a floor core, pending the application. This ability will vary based on type, size, location of the floor core.

Finish and grain matched on tables with multi-piece tops  
 Undermount power units finished in metallic black powder (MC12).  
 Tops pre-drilled for installation of undermount power.  
 Undermount power unit comes with (x1) dual AC hardwire (HW) or plug in(PI) power module and (x2) single space blank plates. For additional connectivity please contact sales person.  
 Top-mount power is available in 5 finishes:  
 Black = ECB  
 White = ECGW  
 Silver = ECS  
 Brushed Aluminum = ECAL  
 Stainless Steel = ECSS.

# Rectangular Media Tables

**42" Deep Tops**  
**2" Thick Top, 6" Wide Bases**

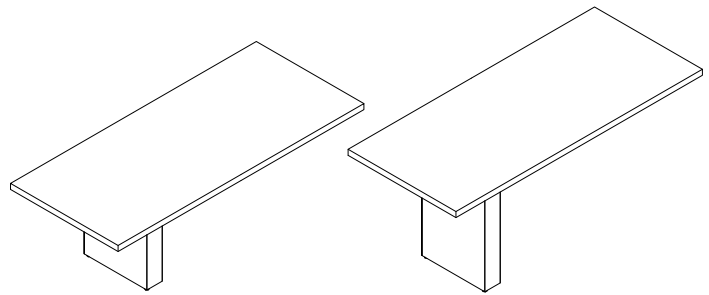

Type	D	W	H	Pattern No.	TP1	TP2	T1 Upcharge	T2 Upcharge
1 (60") top, 1 (6") Base	42"	60"	29 ¼"	<b>07MR42X60V2630</b>	\$7,265	\$7,656	\$448	\$628
1 (72") top, 1 (6") Base	42"	72"	29 ¼"	<b>07MR42X72V2630</b>	7,401	7,800	448	628
1 (84") top, 1 (6") Base	42"	84"	29 ¼"	<b>07MR42X84V2630</b>	7,407	7,809	448	628
2 (48") tops, 1 (6") Base	42"	96"	29 ¼"	<b>07MR42X96V2630</b>	7,546	7,957	448	628
1 (60") top, 1 (6") Base	42"	60"	40 ½"	<b>07MR42X60V2642</b>	7,721	8,146	448	628
1 (72") top, 1 (6") Base	42"	72"	40 ½"	<b>07MR42X72V2642</b>	7,853	8,291	448	628
1 (84") top, 1 (6") Base	42"	84"	40 ½"	<b>07MR42X84V2642</b>	7,872	8,310	448	628
2 (48") tops, 1 (6") Base	42"	96"	40 ½"	<b>07MR42X96V2642</b>	8,009	8,457	448	628

Order Code	Specification Information	Pricing Tiers
Example: <b>07MR42X60V2630</b>	To order please specify pattern number including:	<b>T1P</b> = Tier 1 veneer top with painted base
<b>07</b> JD Collection	1. Top finish: ( )	<b>T2P</b> = Tier 2 veneer top with painted bases
<b>MR</b> Media Table Rectangular	2. Base finish: ( )	<b>T1</b> = Upcharge from T1P for Tier 1 veneer bases
<b>42X</b> Depth	3. Power and connectivity (Optional, blank for none):	<b>T2</b> = Upcharge from T2P for Tier 2 veneer bases
<b>60</b> Width	<b>UMHW</b> Under-mount, Hardwire.	
<b>V</b> Veneer	<b>UMPI</b> Under-mount, Plug in.	
<b>2</b> 2" thick top	<b>UMLK</b> Under-mount, Linkable.	
<b>6</b> 6" wide base	<b>TSHW</b> Top-mount Small, Hardwired.	
<b>30</b> Height	<b>TSPI</b> Top-mount Small, Plug in.	
	<b>TLHW</b> Top-mount Large, Hardwired.	
	<b>TLPI</b> Top-mount Large, Plug in.	

Please refer to Materials and Finishes [page 7](#) for specification details. Please refer to Accessories [page 81](#) for specification details.

### Application Notes

Tables comes with only one base.  
 Under-mount and slide-out power is always Black.  
 Tables ship knocked-down, assembly required.  
 Tables come with structural metal aprons, finished in metallic black powder (MC12).  
 Wire management handled vertically through bases and horizontally through aprons.  
 Bases can fully or partially conceal a floor core, pending the application. This ability will vary based on type, size, location of the floor core.

Finish and grain matched on tables with multi-piece tops  
 Undermount power units finished in metallic black powder (MC12).  
 Tops pre-drilled for installation of undermount power.  
 Undermount power unit comes with (x1) dual AC hardwire (HW) or plug in(PI) power module and (x2) single space blank plates. For additional connectivity please contact sales person.  
 Top-mount power is available in 5 finishes:  
 Black = ECB  
 White = ECGW  
 Silver = ECS  
 Brushed Aluminum = ECAL  
 Stainless Steel = ECSS.

# Rectangular Media Tables

**48" Deep Tops**

**1 1/4" Thick Top, 3 1/2" Wide Bases**

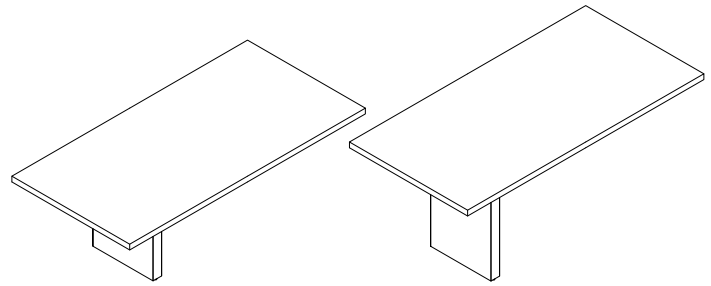

Type	D	W	H	Pattern No.	TP1	TP2	T1 Upcharge	T2 Upcharge
1 (60") top, 1 (3 1/2") Base	48"	60"	29 1/4"	<b>07MR48X60V1330</b>	\$6,244	\$6,551	\$448	\$628
1 (72") top, 1 (3 1/2") Base	48"	72"	29 1/4"	<b>07MR48X72V1330</b>	6,347	6,664	448	628
1 (84") top, 1 (3 1/2") Base	48"	84"	29 1/4"	<b>07MR48X84V1330</b>	6,366	6,684	448	628
2 (48") tops, 1 (3 1/2") Base	48"	96"	29 1/4"	<b>07MR48X96V1330</b>	6,471	6,797	448	628
1 (60") top, 1 (3 1/2") Base	48"	60"	40 1/2"	<b>07MR48X60V1342</b>	6,768	7,117	448	628
1 (72") top, 1 (3 1/2") Base	48"	72"	40 1/2"	<b>07MR48X72V1342</b>	6,862	7,218	448	628
1 (84") top, 1 (3 1/2") Base	48"	84"	40 1/2"	<b>07MR48X84V1342</b>	6,899	7,260	448	628
2 (48") tops, 1 (3 1/2") Base	48"	96"	40 1/2"	<b>07MR48X96V1342</b>	6,995	7,363	448	628

Order Code	Specification Information	Pricing Tiers
Example: <b>07MR48X60V1330</b>	To order please specify pattern number including: 1. Top finish: ( ) 2. Base finish: ( ) 3. Power and connectivity (Optional, blank for none): <b>UMHW</b> Under-mount, Hardwire. <b>UMPI</b> Under-mount, Plug in. <b>UMLK</b> Under-mount, Linkable. <b>TSHW</b> Top-mount Small, Hardwired. <b>TSPI</b> Top-mount Small, Plug in. <b>TLHW</b> Top-mount Large, Hardwired. <b>TLPI</b> Top-mount Large, Plug in.	<b>T1P</b> = Tier 1 veneer top with painted base <b>T2P</b> = Tier 2 veneer top with painted bases <b>T1</b> = Upcharge from T1P for Tier 1 veneer bases <b>T2</b> = Upcharge from T2P for Tier 2 veneer bases
<b>07</b> JD Collection		Please refer to Materials and Finishes <a href="#">page 7</a> for specification details. Please refer to Accessories <a href="#">page 81</a> for specification details.
<b>MR</b> Media Table Rectangular		
<b>48X</b> Depth		
<b>60</b> Width		
<b>V</b> Veneer		
<b>1</b> 1 1/4" thick top		
<b>3</b> 3 1/2" wide base		
<b>30</b> Height		

### Application Notes

Tables comes with only one base.  
Under-mount and slide-out power is always Black.  
Tables ship knocked-down, assembly required.  
Tables come with structural metal aprons, finished in metallic black powder (MC12).  
Wire management handled vertically through bases and horizontally through aprons.  
Bases can fully or partially conceal a floor core, pending the application. This ability will vary based on type, size, location of the floor core.

Finish and grain matched on tables with multi-piece tops  
Undermount power units finished in metallic black powder (MC12).  
Tops pre-drilled for installation of undermount power.  
Undermount power unit comes with (x1) dual AC hardwire (HW) or plug in(PI) power module and (x2) single space blank plates. For additional connectivity please contact sales person.  
Top-mount power is available in 5 finishes:  
Black = ECB  
White = ECGW  
Silver = ECS  
Brushed Aluminum = ECAL  
Stainless Steel = ECSS.



# Rectangular Media Tables

**48" Deep Tops**  
**2" Thick Top, 3 1/2" Wide Bases**

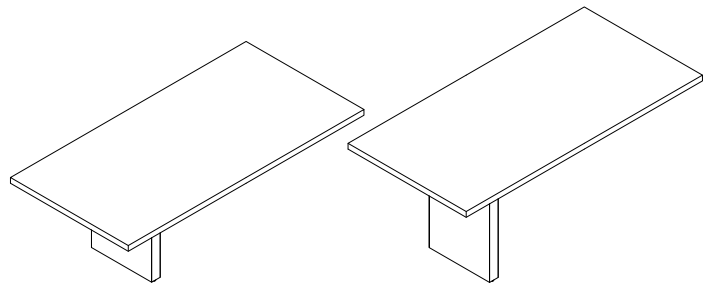

Type	D	W	H	Pattern No.	TP1	TP2	T1 Upcharge	T2 Upcharge
1 (60") top, 1 (3 1/2") Base	48"	60"	29 1/4"	<b>07MR48X60V2330</b>	\$6,674	\$7,016	\$448	\$628
1 (72") top, 1 (3 1/2") Base	48"	72"	29 1/4"	<b>07MR48X72V2330</b>	6,813	7,165	448	628
1 (84") top, 1 (3 1/2") Base	48"	84"	29 1/4"	<b>07MR48X84V2330</b>	6,805	7,158	448	628
2 (48") tops, 1 (3 1/2") Base	48"	96"	29 1/4"	<b>07MR48X96V2330</b>	6,945	7,309	448	628
1 (60") top, 1 (3 1/2") Base	48"	60"	40 1/2"	<b>07MR48X60V2342</b>	7,190	7,574	448	628
1 (72") top, 1 (3 1/2") Base	48"	72"	40 1/2"	<b>07MR48X72V2342</b>	7,331	7,727	448	628
1 (84") top, 1 (3 1/2") Base	48"	84"	40 1/2"	<b>07MR48X84V2342</b>	7,330	7,724	448	628
2 (48") tops, 1 (3 1/2") Base	48"	96"	40 1/2"	<b>07MR48X96V2342</b>	7,475	7,881	448	628

Order Code	Specification Information	Pricing Tiers
Example: <b>07MR48X60V2330</b>	To order please specify pattern number including: 1. Top finish: ( ) 2. Base finish: ( ) 3. Power and connectivity (Optional, blank for none): <b>UMHW</b> Under-mount, Hardwire. <b>UMPI</b> Under-mount, Plug in. <b>UMLK</b> Under-mount, Linkable. <b>TSHW</b> Top-mount Small, Hardwired. <b>TSPI</b> Top-mount Small, Plug in. <b>TLHW</b> Top-mount Large, Hardwired. <b>TLPI</b> Top-mount Large, Plug in.	<b>T1P</b> = Tier 1 veneer top with painted base <b>T2P</b> = Tier 2 veneer top with painted bases <b>T1</b> = Upcharge from T1P for Tier 1 veneer bases <b>T2</b> = Upcharge from T2P for Tier 2 veneer bases
<b>07</b> JD Collection		Please refer to Materials and Finishes <a href="#">page 7</a> for specification details. Please refer to Accessories <a href="#">page 81</a> for specification details.
<b>MR</b> Media Table Rectangular		
<b>48X</b> Depth		
<b>60</b> Width		
<b>V</b> Veneer		
<b>2</b> 2" thick top		
<b>3</b> 3 1/2" wide base		
<b>30</b> Height		

### Application Notes

Tables comes with only one base.  
 Under-mount and slide-out power is always Black.  
 Tables ship knocked-down, assembly required.  
 Tables come with structural metal aprons, finished in metallic black powder (MC12).  
 Wire management handled vertically through bases and horizontally through aprons.  
 Bases can fully or partially conceal a floor core, pending the application. This ability will vary based on type, size, location of the floor core.

Finish and grain matched on tables with multi-piece tops  
 Undermount power units finished in metallic black powder (MC12).  
 Tops pre-drilled for installation of undermount power.  
 Undermount power unit comes with (x1) dual AC hardwire (HW) or plug in(PI) power module and (x2) single space blank plates. For additional connectivity please contact sales person.  
 Top-mount power is available in 5 finishes:  
 Black = ECB  
 White = ECGW  
 Silver = ECS  
 Brushed Aluminum = ECAL  
 Stainless Steel = ECSS.

# Rectangular Media Tables

**48" Deep Tops**

**1 1/4" Thick Top, 6" Wide Bases**

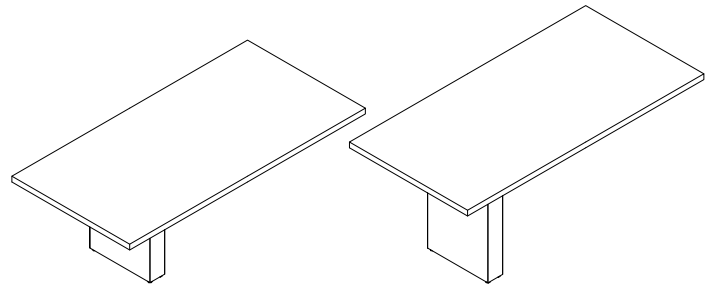

Type	D	W	H	Pattern No.	TP1	TP2	T1 Upcharge	T2 Upcharge
1 (60") top, 1 (6") Base	48"	60"	29 1/4"	<b>07MR48X60V1630</b>	\$7,284	\$7,674	\$448	\$628
1 (72") top, 1 (6") Base	48"	72"	29 1/4"	<b>07MR48X72V1630</b>	7,383	7,781	448	628
1 (84") top, 1 (6") Base	48"	84"	29 1/4"	<b>07MR48X84V1630</b>	7,426	7,828	448	628
2 (48") tops, 1 (6") Base	48"	96"	29 1/4"	<b>07MR48X96V1630</b>	7,527	7,939	448	628
1 (60") top, 1 (6") Base	48"	60"	40 1/2"	<b>07MR48X60V1642</b>	7,797	8,227	448	628
1 (72") top, 1 (6") Base	48"	72"	40 1/2"	<b>07MR48X72V1642</b>	7,898	8,339	448	628
1 (84") top, 1 (6") Base	48"	84"	40 1/2"	<b>07MR48X84V1642</b>	7,949	8,392	448	628
2 (48") tops, 1 (6") Base	48"	96"	40 1/2"	<b>07MR48X96V1642</b>	8,052	8,506	448	628

Order Code	Specification Information	Pricing Tiers
Example: <b>07MR48X60V1630</b>	To order please specify pattern number including:	<b>T1P</b> = Tier 1 veneer top with painted base
<b>07</b> JD Collection	1. Top finish: ( )	<b>T2P</b> = Tier 2 veneer top with painted bases
<b>MR</b> Media Table Rectangular	2. Base finish: ( )	<b>T1</b> = Upcharge from T1P for Tier 1 veneer bases
<b>48X</b> Depth	3. Power and connectivity (Optional, blank for none):	<b>T2</b> = Upcharge from T2P for Tier 2 veneer bases
<b>60</b> Width	<b>UMHW</b> Under-mount, Hardwire.	
<b>V</b> Veneer	<b>UMPI</b> Under-mount, Plug in.	
<b>1</b> 1 1/4" thick top	<b>UMLK</b> Under-mount, Linkable.	
<b>6</b> 6" wide base	<b>TSHW</b> Top-mount Small, Hardwired.	
<b>30</b> Height	<b>TSPI</b> Top-mount Small, Plug in.	
	<b>TLHW</b> Top-mount Large, Hardwired.	
	<b>TLPI</b> Top-mount Large, Plug in.	

Please refer to Materials and Finishes [page 7](#) for specification details. Please refer to Accessories [page 81](#) for specification details.

### Application Notes

Tables comes with only one base.  
 Under-mount and slide-out power is always Black.  
 Tables ship knocked-down, assembly required.  
 Tables come with structural metal aprons, finished in metallic black powder (MC12).  
 Wire management handled vertically through bases and horizontally through aprons.  
 Bases can fully or partially conceal a floor core, pending the application. This ability will vary based on type, size, location of the floor core.

Finish and grain matched on tables with multi-piece tops  
 Undermount power units finished in metallic black powder (MC12).  
 Tops pre-drilled for installation of undermount power.  
 Undermount power unit comes with (x1) dual AC hardwire (HW) or plug in(PI) power module and (x2) single space blank plates. For additional connectivity please contact sales person.  
 Top-mount power is available in 5 finishes:  
 Black = ECB  
 White = ECGW  
 Silver = ECS  
 Brushed Aluminum = ECAL  
 Stainless Steel = ECSS.

# Rectangular Media Tables

**48" Deep Tops**  
**2" Thick Top, 6" Wide Bases**

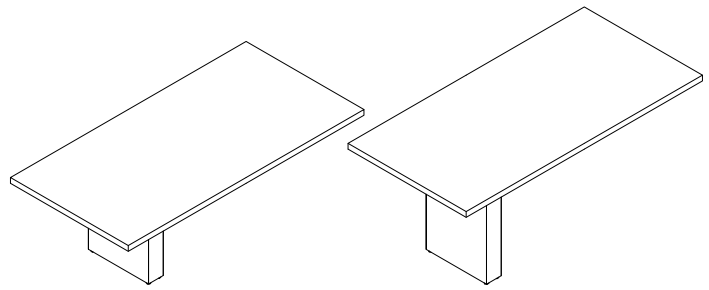

Type	D	W	H	Pattern No.	TP1	TP2	T1 Upcharge	T2 Upcharge
1 (60") top, 1 (6") Base	48"	60"	29 ¼"	<b>07MR48X60V2630</b>	\$7,706	\$8,131	\$448	\$628
1 (72") top, 1 (6") Base	48"	72"	29 ¼"	<b>07MR48X72V2630</b>	7,844	8,279	448	628
1 (84") top, 1 (6") Base	48"	84"	29 ¼"	<b>07MR48X84V2630</b>	7,858	8,294	448	628
2 (48") tops, 1 (6") Base	48"	96"	29 ¼"	<b>07MR48X96V2630</b>	7,997	8,444	448	628
1 (60") top, 1 (6") Base	48"	60"	40 ½"	<b>07MR48X60V2642</b>	8,221	8,687	448	628
1 (72") top, 1 (6") Base	48"	72"	40 ½"	<b>07MR48X72V2642</b>	8,356	8,833	448	628
1 (84") top, 1 (6") Base	48"	84"	40 ½"	<b>07MR48X84V2642</b>	8,383	8,860	448	628
2 (48") tops, 1 (6") Base	48"	96"	40 ½"	<b>07MR48X96V2642</b>	8,519	9,009	448	628

Order Code	Specification Information	Pricing Tiers
Example: <b>07MR48X60V2630</b>	To order please specify pattern number including:	<b>T1P</b> = Tier 1 veneer top with painted base
<b>07</b> JD Collection	1. Top finish: ( )	<b>T2P</b> = Tier 2 veneer top with painted bases
<b>MR</b> Media Table Rectangular	2. Base finish: ( )	<b>T1</b> = Upcharge from T1P for Tier 1 veneer bases
<b>48X</b> Depth	3. Power and connectivity (Optional, blank for none):	<b>T2</b> = Upcharge from T2P for Tier 2 veneer bases
<b>60</b> Width	<b>UMHW</b> Under-mount, Hardwire.	
<b>V</b> Veneer	<b>UMPI</b> Under-mount, Plug in.	
<b>2</b> 2" thick top	<b>UMLK</b> Under-mount, Linkable.	
<b>6</b> 6" wide base	<b>TSHW</b> Top-mount Small, Hardwired.	
<b>30</b> Height	<b>TSPI</b> Top-mount Small, Plug in.	
	<b>TLHW</b> Top-mount Large, Hardwired.	
	<b>TLPI</b> Top-mount Large, Plug in.	

**Application Notes**

Tables comes with only one base.  
 Under-mount and slide-out power is always Black.  
 Tables ship knocked-down, assembly required.  
 Tables come with structural metal aprons, finished in metallic black powder (MC12).  
 Wire management handled vertically through bases and horizontally through aprons.  
 Bases can fully or partially conceal a floor core, pending the application. This ability will vary based on type, size, location of the floor core.

Finish and grain matched on tables with multi-piece tops  
 Undermount power units finished in metallic black powder (MC12).  
 Tops pre-drilled for installation of undermount power.  
 Undermount power unit comes with (x1) dual AC hardwire (HW) or plug in(PI) power module and (x2) single space blank plates. For additional connectivity please contact sales person.  
 Top-mount power is available in 5 finishes:  
 Black = ECB  
 White = ECGW  
 Silver = ECS  
 Brushed Aluminum = ECAL  
 Stainless Steel = ECSS.

# Rectangular Media Tables

**54" Deep Tops**

**1 1/4" Thick Top, 3 1/2" Wide Bases**

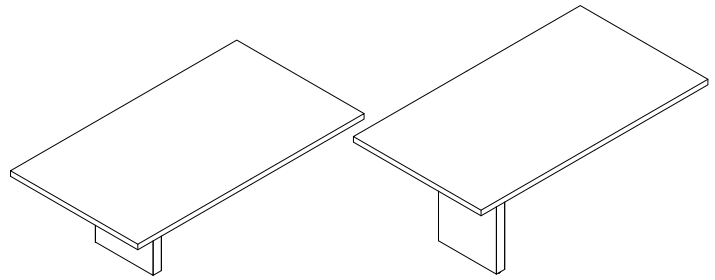

Type	D	W	H	Pattern No.	TP1	TP2	T1 Upcharge	T2 Upcharge
1 (60") top, 1 (3 1/2") Base	54"	60"	29 1/4"	<b>07MR54X60V1330</b>	\$5,927	\$6,209	\$448	\$628
1 (72") top, 1 (3 1/2") Base	54"	72"	29 1/4"	<b>07MR54X72V1330</b>	6,670	7,013	448	628
1 (84") top, 1 (3 1/2") Base	54"	84"	29 1/4"	<b>07MR54X84V1330</b>	6,043	6,334	448	628
2 (48") tops, 1 (3 1/2") Base	54"	96"	29 1/4"	<b>07MR54X96V1330</b>	6,801	7,154	448	628
1 (60") top, 1 (3 1/2") Base	54"	60"	40 1/2"	<b>07MR54X60V1342</b>	7,145	7,525	448	628
1 (72") top, 1 (3 1/2") Base	54"	72"	40 1/2"	<b>07MR54X72V1342</b>	7,242	7,630	448	628
1 (84") top, 1 (3 1/2") Base	54"	84"	40 1/2"	<b>07MR54X84V1342</b>	7,285	7,675	448	628
2 (48") tops, 1 (3 1/2") Base	54"	96"	40 1/2"	<b>07MR54X96V1342</b>	7,384	7,783	448	628

Order Code	Specification Information	Pricing Tiers
Example: <b>07MR54X60V1330</b>	To order please specify pattern number including:	<b>T1P</b> = Tier 1 veneer top with painted base
<b>07</b> JD Collection	1. Top finish: ( )	<b>T2P</b> = Tier 2 veneer top with painted bases
<b>MR</b> Media Table Rectangular	2. Base finish: ( )	<b>T1</b> = Upcharge from T1P for Tier 1 veneer bases
<b>54X</b> Depth	3. Power and connectivity (Optional, blank for none):	<b>T2</b> = Upcharge from T2P for Tier 2 veneer bases
<b>60</b> Width	<b>UMHW</b> Under-mount, Hardwire.	
<b>V</b> Veneer	<b>UMPI</b> Under-mount, Plug in.	
<b>1</b> 1 1/4" thick top	<b>UMLK</b> Under-mount, Linkable.	
<b>3</b> 3 1/2" wide base	<b>TSHW</b> Top-mount Small, Hardwired.	
<b>30</b> Height	<b>TSPI</b> Top-mount Small, Plug in.	
	<b>TLHW</b> Top-mount Large, Hardwired.	
	<b>TLPI</b> Top-mount Large, Plug in.	

### Application Notes

Tables comes with only one base.  
 Under-mount and slide-out power is always Black.  
 Tables ship knocked-down, assembly required.  
 Tables come with structural metal aprons, finished in metallic black powder (MC12).  
 Wire management handled vertically through bases and horizontally through aprons.  
 Bases can fully or partially conceal a floor core, pending the application. This ability will vary based on type, size, location of the floor core.

Finish and grain matched on tables with multi-piece tops  
 Undermount power units finished in metallic black powder (MC12).  
 Tops pre-drilled for installation of undermount power.  
 Undermount power unit comes with (x1) dual AC hardwire (HW) or plug in(PI) power module and (x2) single space blank plates. For additional connectivity please contact sales person.  
 Top-mount power is available in 5 finishes:  
 Black = ECB  
 White = ECGW  
 Silver = ECS  
 Brushed Aluminum = ECAL  
 Stainless Steel = ECSS.

# Rectangular Media Tables

**54" Deep Tops**

**2" Thick Top, 3 1/2" Wide Bases**

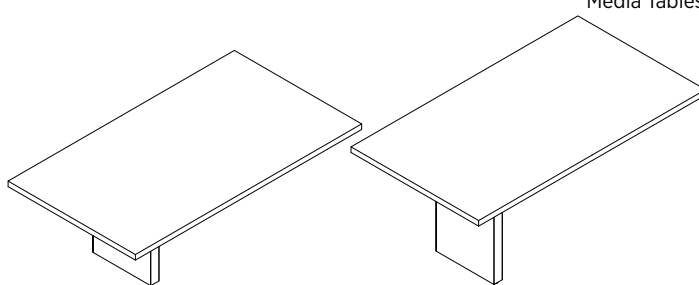

Type	D	W	H	Pattern No.	TP1	TP2	T1 Upcharge	T2 Upcharge
1 (60") top, 1 (3 1/2") Base	54"	60"	29 1/4"	<b>07MR54X60V2330</b>	\$6,986	\$7,355	\$448	\$628
1 (72") top, 1 (3 1/2") Base	54"	72"	29 1/4"	<b>07MR54X72V2330</b>	7,126	7,505	448	628
1 (84") top, 1 (3 1/2") Base	54"	84"	29 1/4"	<b>07MR54X84V2330</b>	7,124	7,501	448	628
2 (48") tops, 1 (3 1/2") Base	54"	96"	29 1/4"	<b>07MR54X96V2330</b>	7,264	7,654	448	628
1 (60") top, 1 (3 1/2") Base	54"	60"	40 1/2"	<b>07MR54X60V2342</b>	7,574	7,989	448	628
1 (72") top, 1 (3 1/2") Base	54"	72"	40 1/2"	<b>07MR54X72V2342</b>	7,703	8,127	448	628
1 (84") top, 1 (3 1/2") Base	54"	84"	40 1/2"	<b>07MR54X84V2342</b>	7,721	8,148	448	628
2 (48") tops, 1 (3 1/2") Base	54"	96"	40 1/2"	<b>07MR54X96V2342</b>	7,853	8,291	448	628

Order Code	Specification Information	Pricing Tiers
Example: <b>07MR54X60V2330</b>	To order please specify pattern number including:	<b>T1P</b> = Tier 1 veneer top with painted base
<b>07</b> JD Collection	1. Top finish: ( )	<b>T2P</b> = Tier 2 veneer top with painted bases
<b>MR</b> Media Table Rectangular	2. Base finish: ( )	<b>T1</b> = Upcharge from T1P for Tier 1 veneer bases
<b>54X</b> Depth	3. Power and connectivity (Optional, blank for none):	<b>T2</b> = Upcharge from T2P for Tier 2 veneer bases
<b>60</b> Width	<b>UMHW</b> Under-mount, Hardwire.	
<b>V</b> Veneer	<b>UMPI</b> Under-mount, Plug in.	
<b>2</b> 2" thick top	<b>UMLK</b> Under-mount, Linkable.	
<b>3</b> 3 1/2" wide base	<b>TSHW</b> Top-mount Small, Hardwired.	
<b>30</b> Height	<b>TSPI</b> Top-mount Small, Plug in.	
	<b>TLHW</b> Top-mount Large, Hardwired.	
	<b>TLPI</b> Top-mount Large, Plug in.	

Please refer to Materials and Finishes [page 7](#) for specification details. Please refer to Accessories [page 81](#) for specification details.

## Application Notes

Tables comes with only one base.  
 Under-mount and slide-out power is always Black.  
 Tables ship knocked-down, assembly required.  
 Tables come with structural metal aprons, finished in metallic black powder (MC12).  
 Wire management handled vertically through bases and horizontally through aprons.  
 Bases can fully or partially conceal a floor core, pending the application. This ability will vary based on type, size, location of the floor core.

Finish and grain matched on tables with multi-piece tops  
 Undermount power units finished in metallic black powder (MC12).  
 Tops pre-drilled for installation of undermount power.  
 Undermount power unit comes with (x1) dual AC hardwire (HW) or plug in(PI) power module and (x2) single space blank plates. For additional connectivity please contact sales person.  
 Top-mount power is available in 5 finishes:  
 Black = ECB  
 White = ECGW  
 Silver = ECS  
 Brushed Aluminum = ECAL  
 Stainless Steel = ECSS.

# Rectangular Media Tables

**54" Deep Tops**

**1 1/4" Thick Top, 6" Wide Bases**

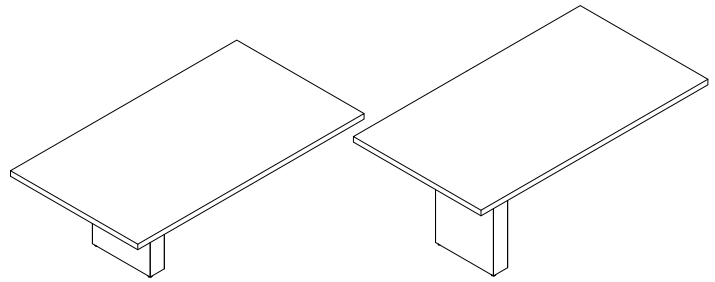

Type	D	W	H	Pattern No.	TP1	TP2	T1 Upcharge	T2 Upcharge
1 (60") top, 1 (6") Base	54"	60"	29 1/4"	<b>07MR54X60V1630</b>	\$7,727	\$8,153	\$448	\$628
1 (72") top, 1 (6") Base	54"	72"	29 1/4"	<b>07MR54X72V1630</b>	7,826	8,260	448	628
1 (84") top, 1 (6") Base	54"	84"	29 1/4"	<b>07MR54X84V1630</b>	7,877	8,316	448	628
2 (48") tops, 1 (6") Base	54"	96"	29 1/4"	<b>07MR54X96V1630</b>	7,979	8,426	448	628
1 (60") top, 1 (6") Base	54"	60"	40 1/2"	<b>07MR54X60V1642</b>	8,301	8,773	448	628
1 (72") top, 1 (6") Base	54"	72"	40 1/2"	<b>07MR54X72V1642</b>	8,403	8,883	448	628
1 (84") top, 1 (6") Base	54"	84"	40 1/2"	<b>07MR54X84V1642</b>	8,462	8,949	448	628
2 (48") tops, 1 (6") Base	54"	96"	40 1/2"	<b>07MR54X96V1642</b>	8,567	9,060	448	628

Order Code	Specification Information	Pricing Tiers
Example: <b>07MR54X60V1630</b>	To order please specify pattern number including:	<b>T1P</b> = Tier 1 veneer top with painted base
<b>07</b> JD Collection	1. Top finish: ( )	<b>T2P</b> = Tier 2 veneer top with painted bases
<b>MR</b> Media Table Rectangular	2. Base finish: ( )	<b>T1</b> = Upcharge from T1P for Tier 1 veneer bases
<b>54X</b> Depth	3. Power and connectivity (Optional, blank for none):	<b>T2</b> = Upcharge from T2P for Tier 2 veneer bases
<b>60</b> Width	<b>UMHW</b> Under-mount, Hardwire.	
<b>V</b> Veneer	<b>UMPI</b> Under-mount, Plug in.	
<b>1</b> 1 1/4" thick top	<b>UMLK</b> Under-mount, Linkable.	
<b>6</b> 6" wide base	<b>TSHW</b> Top-mount Small, Hardwired.	
<b>30</b> Height	<b>TSPI</b> Top-mount Small, Plug in.	
	<b>TLHW</b> Top-mount Large, Hardwired.	
	<b>TLPI</b> Top-mount Large, Plug in.	

Please refer to Materials and Finishes [page 7](#) for specification details. Please refer to Accessories [page 81](#) for specification details.

### Application Notes

Tables comes with only one base.  
 Under-mount and slide-out power is always Black.  
 Tables ship knocked-down, assembly required.  
 Tables come with structural metal aprons, finished in metallic black powder (MC12).  
 Wire management handled vertically through bases and horizontally through aprons.  
 Bases can fully or partially conceal a floor core, pending the application. This ability will vary based on type, size, location of the floor core.

Finish and grain matched on tables with multi-piece tops  
 Undermount power units finished in metallic black powder (MC12).  
 Tops pre-drilled for installation of undermount power.  
 Undermount power unit comes with (x1) dual AC hardwire (HW) or plug in(PI) power module and (x2) single space blank plates. For additional connectivity please contact sales person.  
 Top-mount power is available in 5 finishes:  
 Black = ECB  
 White = ECGW  
 Silver = ECS  
 Brushed Aluminum = ECAL  
 Stainless Steel = ECSS.

# Rectangular Media Tables

**54" Deep Tops**  
**2" Thick Top, 6" Wide Bases**

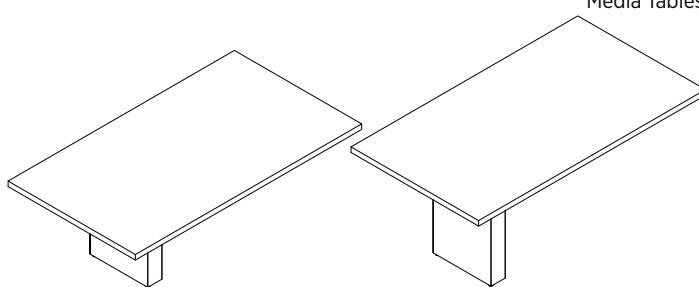

Type	D	W	H	Pattern No.	TP1	TP2	T1 Upcharge	T2 Upcharge
1 (60") top, 1 (6") Base	54"	60"	29 ¼"	<b>07MR54X60V2630</b>	\$8,150	\$8,611	\$448	\$628
1 (72") top, 1 (6") Base	54"	72"	29 ¼"	<b>07MR54X72V2630</b>	8,290	8,761	448	628
1 (84") top, 1 (6") Base	54"	84"	29 ¼"	<b>07MR54X84V2630</b>	8,310	8,783	448	628
2 (48") tops, 1 (6") Base	54"	96"	29 ¼"	<b>07MR54X96V2630</b>	8,453	8,936	448	628
1 (60") top, 1 (6") Base	54"	60"	40 ½"	<b>07MR54X60V2642</b>	8,727	9,232	448	628
1 (72") top, 1 (6") Base	54"	72"	40 ½"	<b>07MR54X72V2642</b>	8,866	9,384	448	628
1 (84") top, 1 (6") Base	54"	84"	40 ½"	<b>07MR54X84V2642</b>	8,898	9,418	448	628
2 (48") tops, 1 (6") Base	54"	96"	40 ½"	<b>07MR54X96V2642</b>	9,040	9,572	448	628

Order Code	Specification Information	Pricing Tiers
Example: <b>07MR54X60V2630</b>	To order please specify pattern number including:	<b>T1P</b> = Tier 1 veneer top with painted base
<b>07</b> JD Collection	1. Top finish: ( )	<b>T2P</b> = Tier 2 veneer top with painted bases
<b>MR</b> Media Table Rectangular	2. Base finish: ( )	<b>T1</b> = Upcharge from T1P for Tier 1 veneer bases
<b>54X</b> Depth	3. Power and connectivity (Optional, blank for none):	<b>T2</b> = Upcharge from T2P for Tier 2 veneer bases
<b>60</b> Width	<b>UMHW</b> Under-mount, Hardwire.	
<b>V</b> Veneer	<b>UMPI</b> Under-mount, Plug in.	
<b>2</b> 2" thick top	<b>UMLK</b> Under-mount, Linkable.	
<b>6</b> 6" wide base	<b>TSHW</b> Top-mount Small, Hardwired.	
<b>30</b> Height	<b>TSPI</b> Top-mount Small, Plug in.	
	<b>TLHW</b> Top-mount Large, Hardwired.	
	<b>TLPI</b> Top-mount Large, Plug in.	

### Application Notes

Tables comes with only one base.  
 Under-mount and slide-out power is always Black.  
 Tables ship knocked-down, assembly required.  
 Tables come with structural metal aprons, finished in metallic black powder (MC12).  
 Wire management handled vertically through bases and horizontally through aprons.  
 Bases can fully or partially conceal a floor core, pending the application. This ability will vary based on type, size, location of the floor core.

Finish and grain matched on tables with multi-piece tops  
 Undermount power units finished in metallic black powder (MC12).  
 Tops pre-drilled for installation of undermount power.  
 Undermount power unit comes with (x1) dual AC hardwire (HW) or plug in(PI) power module and (x2) single space blank plates. For additional connectivity please contact sales person.  
 Top-mount power is available in 5 finishes:  
 Black = ECB  
 White = ECGW  
 Silver = ECS  
 Brushed Aluminum = ECAL  
 Stainless Steel = ECSS.

# Trapezoid Media Tables

**42"-54" Deep Tops**

**1 1/4" Thick Top, 3 1/2" Wide Bases**

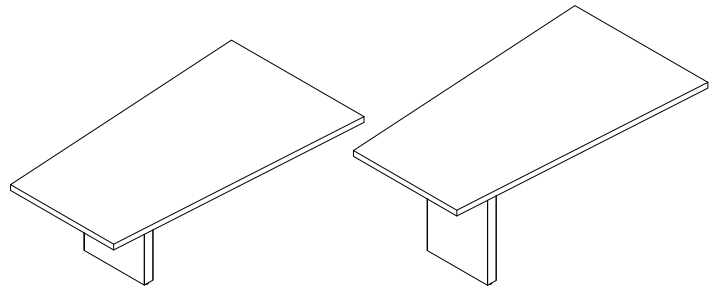

Type	D	W	H	Pattern No.	TP1	TP2	Upcharge	T1	T2
1 (60") top, 1 (3 1/2") Base	42"/54"	60"	29 1/4"	<b>07MT4254X60V1330</b>	\$5,927	\$6,209	\$448	\$628	
1 (72") top, 1 (3 1/2") Base	42"/54"	72"	29 1/4"	<b>07MT4254X72V1330</b>	6,034	6,334	448	628	
1 (84") top, 1 (3 1/2") Base	42"/54"	84"	29 1/4"	<b>07MT4254X84V1330</b>	6,670	7,013	448	628	
2 (48") tops, 1 (3 1/2") Base	42"/54"	96"	29 1/4"	<b>07MT4254X96V1330</b>	6,801	7,154	448	628	
1 (60") top, 1 (3 1/2") Base	42"/54"	60"	40 1/2"	<b>07MT4254X60V1342</b>	7,145	7,525	448	628	
1 (72") top, 1 (3 1/2") Base	42"/54"	72"	40 1/2"	<b>07MT4254X72V1342</b>	7,242	7,630	448	628	
1 (84") top, 1 (3 1/2") Base	42"/54"	84"	40 1/2"	<b>07MT4254X84V1342</b>	7,285	7,675	448	628	
2 (48") tops, 1 (3 1/2") Base	42"/54"	96"	40 1/2"	<b>07MT4254X96V1342</b>	7,384	7,783	448	628	

Order Code	Specification Information	Pricing Tiers
Example: <b>07MT4254X60V1330</b>	To order please specify pattern number including: 1. Top finish: ( ) 2. Base finish: ( ) 3. Power and connectivity (Optional, blank for none):	<b>T1P</b> = Tier 1 veneer top with painted base <b>T2P</b> = Tier 2 veneer top with painted bases <b>T1</b> = Upcharge from T1P for Tier 1 veneer bases <b>T2</b> = Upcharge from T2P for Tier 2 veneer bases
<b>07</b> JD Collection	<b>UMHW</b> Under-mount, Hardwire.	Please refer to Materials and Finishes <a href="#">page 7</a> for specification details. Please refer to Accessories <a href="#">page 81</a> for specification details.
<b>MT</b> Media Table Trapezoid	<b>UMPI</b> Under-mount, Plug in.	
<b>4254X</b> Depth	<b>UMLK</b> Under-mount, Linkable.	
<b>60</b> Width	<b>TSHW</b> Top-mount Small, Hardwired.	
<b>V</b> Veneer	<b>TSPI</b> Top-mount Small, Plug in.	
<b>1</b> 1 1/4" thick top	<b>TLHW</b> Top-mount Large, Hardwired.	
<b>3</b> 3 1/2" wide base	<b>TLPI</b> Top-mount Large, Plug in.	
<b>30</b> Height		

### Application Notes

Tables comes with only one base.  
Under-mount and slide-out power is always Black.  
Tables ship knocked-down, assembly required.  
Tables come with structural metal aprons, finished in metallic black powder (MC12).  
Wire management handled vertically through bases and horizontally through aprons.  
Bases can fully or partially conceal a floor core, pending the application. This ability will vary based on type, size, location of the floor core.

Finish and grain matched on tables with multi-piece tops  
Undermount power units finished in metallic black powder (MC12).  
Tops pre-drilled for installation of undermount power.  
Undermount power unit comes with (x1) dual AC hardwire (HW) or plug in(PI) power module and (x2) single space blank plates. For additional connectivity please contact sales person.  
Top-mount power is available in 5 finishes:  
Black = ECB  
White = ECGW  
Silver = ECS  
Brushed Aluminum = ECAL  
Stainless Steel = ECSS.



# Trapezoid Media Tables

**42"-54" Deep Tops**

**2" Thick Top, 3 1/2" Wide Bases**

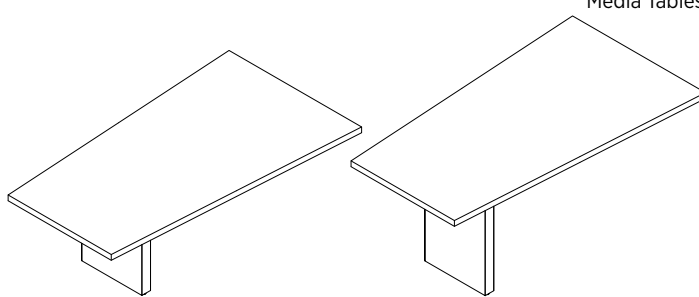

Type	D	W	H	Pattern No.	TP1	TP2	T1 Upcharge	T2 Upcharge
1 (60") top, 1 (3 1/2") Base	42"/54"	60"	29 1/4"	<b>07MT4254X60V2330</b>	\$6,986	\$7,355	\$448	\$628
1 (72") top, 1 (3 1/2") Base	42"/54"	72"	29 1/4"	<b>07MT4254X72V2330</b>	7,126	7,505	448	628
1 (84") top, 1 (3 1/2") Base	42"/54"	84"	29 1/4"	<b>07MT4254X84V2330</b>	7,124	7,501	448	628
2 (48") tops, 1 (3 1/2") Base	42"/54"	96"	29 1/4"	<b>07MT4254X96V2330</b>	7,264	7,654	448	628
1 (60") top, 1 (3 1/2") Base	42"/54"	60"	40 1/2"	<b>07MT4254X60V2342</b>	7,574	7,989	448	628
1 (72") top, 1 (3 1/2") Base	42"/54"	72"	40 1/2"	<b>07MT4254X72V2342</b>	7,703	8,127	448	628
1 (84") top, 1 (3 1/2") Base	42"/54"	84"	40 1/2"	<b>07MT4254X84V2342</b>	7,721	8,148	448	628
2 (48") tops, 1 (3 1/2") Base	42"/54"	96"	40 1/2"	<b>07MT4254X96V2342</b>	7,853	8,291	448	628

Order Code	Specification Information	Pricing Tiers
Example: <b>07MT4254X60V2330</b>	To order please specify pattern number including: 1. Top finish: ( ) 2. Base finish: ( ) 3. Power and connectivity (Optional, blank for none):	<b>T1P</b> = Tier 1 veneer top with painted base <b>T2P</b> = Tier 2 veneer top with painted bases <b>T1</b> = Upcharge from T1P for Tier 1 veneer bases <b>T2</b> = Upcharge from T2P for Tier 2 veneer bases
<b>07</b> JD Collection	<b>UMHW</b> Under-mount, Hardwire.	Please refer to Materials and Finishes <a href="#">page 7</a> for specification details. Please refer to Accessories <a href="#">page 81</a> for specification details.
<b>MT</b> Media Table Trapezoid	<b>UMPI</b> Under-mount, Plug in.	
<b>4254X</b> Depth	<b>UMLK</b> Under-mount, Linkable.	
<b>60</b> Width	<b>TSHW</b> Top-mount Small, Hardwired.	
<b>V</b> Veneer	<b>TSPI</b> Top-mount Small, Plug in.	
<b>2</b> 2" thick top	<b>TLHW</b> Top-mount Large, Hardwired.	
<b>3</b> 3 1/2" wide base	<b>TLPI</b> Top-mount Large, Plug in.	
<b>30</b> Height		

### Application Notes

Tables comes with only one base.  
Under-mount and slide-out power is always Black.  
Tables ship knocked-down, assembly required.  
Tables come with structural metal aprons, finished in metallic black powder (MC12).  
Wire management handled vertically through bases and horizontally through aprons.  
Bases can fully or partially conceal a floor core, pending the application. This ability will vary based on type, size, location of the floor core.

Finish and grain matched on tables with multi-piece tops  
Undermount power units finished in metallic black powder (MC12).  
Tops pre-drilled for installation of undermount power.  
Undermount power unit comes with (x1) dual AC hardwire (HW) or plug in(PI) power module and (x2) single space blank plates. For additional connectivity please contact sales person.  
Top-mount power is available in 5 finishes:  
Black = ECB  
White = ECGW  
Silver = ECS  
Brushed Aluminum = ECAL  
Stainless Steel = ECSS.

# Trapezoid Media Tables

**42"-54" Deep Tops**

**1 1/4" Thick Top, 6" Wide Bases**

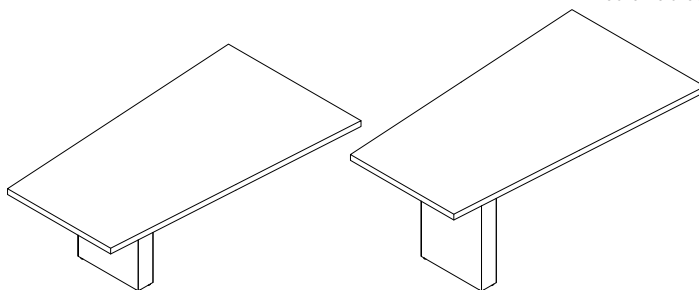

Type	D	W	H	Pattern No.	TP1	TP2	T1 Upcharge	T2 Upcharge
1 (60") top, 1 (6") Base	42"/54"	60"	29 1/4"	<b>07MT4254X60V1630</b>	\$7,727	\$8,153	\$448	\$628
1 (72") top, 1 (6") Base	42"/54"	72"	29 1/4"	<b>07MT4254X72V1630</b>	7,826	8,260	448	628
1 (84") top, 1 (6") Base	42"/54"	84"	29 1/4"	<b>07MT4254X84V1630</b>	7,877	8,316	448	628
2 (48") tops, 1 (6") Base	42"/54"	96"	29 1/4"	<b>07MT4254X96V1630</b>	7,979	8,426	448	628
1 (60") top, 1 (6") Base	42"/54"	60"	40 1/2"	<b>07MT4254X60V1642</b>	8,301	8,773	448	628
1 (72") top, 1 (6") Base	42"/54"	72"	40 1/2"	<b>07MT4254X72V1642</b>	8,403	8,883	448	628
1 (84") top, 1 (6") Base	42"/54"	84"	40 1/2"	<b>07MT4254X84V1642</b>	8,462	8,949	448	628
2 (48") tops, 1 (6") Base	42"/54"	96"	40 1/2"	<b>07MT4254X96V1642</b>	8,567	9,060	448	628

Order Code	Specification Information	Pricing Tiers
Example: <b>07MT4254X60V1630</b>	To order please specify pattern number including: 1. Top finish: ( ) 2. Base finish: ( ) 3. Power and connectivity (Optional, blank for none): <b>UMHW</b> Under-mount, Hardwire. <b>UMPI</b> Under-mount, Plug in. <b>UMLK</b> Under-mount, Linkable. <b>TSHW</b> Top-mount Small, Hardwired. <b>TSPI</b> Top-mount Small, Plug in. <b>TLHW</b> Top-mount Large, Hardwired. <b>TLPI</b> Top-mount Large, Plug in.	<b>T1P</b> = Tier 1 veneer top with painted base <b>T2P</b> = Tier 2 veneer top with painted bases <b>T1</b> = Upcharge from T1P for Tier 1 veneer bases <b>T2</b> = Upcharge from T2P for Tier 2 veneer bases
<b>07</b> JD Collection		Please refer to Materials and Finishes <a href="#">page 7</a> for specification details. Please refer to Accessories <a href="#">page 81</a> for specification details.
<b>MT</b> Media Table Trapezoid		
<b>4254X</b> Depth		
<b>60</b> Width		
<b>V</b> Veneer		
<b>1</b> 1 1/4" thick top		
<b>6</b> 6" wide base		
<b>30</b> Height		

### Application Notes

Tables comes with only one base.  
Under-mount and slide-out power is always Black.  
Tables ship knocked-down, assembly required.  
Tables come with structural metal aprons, finished in metallic black powder (MC12).  
Wire management handled vertically through bases and horizontally through aprons.  
Bases can fully or partially conceal a floor core, pending the application. This ability will vary based on type, size, location of the floor core.

Finish and grain matched on tables with multi-piece tops  
Undermount power units finished in metallic black powder (MC12).  
Tops pre-drilled for installation of undermount power.  
Undermount power unit comes with (x1) dual AC hardwire (HW) or plug in(PI) power module and (x2) single space blank plates. For additional connectivity please contact sales person.  
Top-mount power is available in 5 finishes:  
Black = ECB  
White = ECGW  
Silver = ECS  
Brushed Aluminum = ECAL  
Stainless Steel = ECSS.

# Trapezoid Media Tables

**42"-54" Deep Tops**  
**2" Thick Top, 6" Wide Bases**

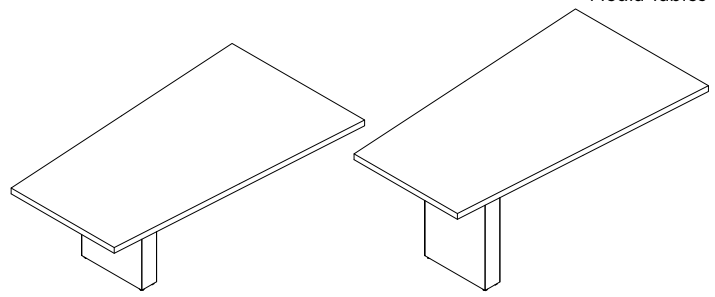

Type	D	W	H	Pattern No.	TP1	TP2	T1 Upcharge	T2 Upcharge
1 (60") top, 1 (6") Base	42"/54"	60"	29 ¼"	<b>07MT4254X60V2630</b>	\$8,150	\$8,611	\$448	\$628
1 (72") top, 1 (6") Base	42"/54"	72"	29 ¼"	<b>07MT4254X72V2630</b>	8,290	8,761	448	628
1 (84") top, 1 (6") Base	42"/54"	84"	29 ¼"	<b>07MT4254X84V2630</b>	8,310	8,783	448	628
2 (48") tops, 1 (6") Base	42"/54"	96"	29 ¼"	<b>07MT4254X96V2630</b>	8,453	8,936	448	628
1 (60") top, 1 (6") Base	42"/54"	60"	40 ½"	<b>07MT4254X60V2642</b>	8,727	9,232	448	628
1 (72") top, 1 (6") Base	42"/54"	72"	40 ½"	<b>07MT4254X72V2642</b>	8,866	9,384	448	628
1 (84") top, 1 (6") Base	42"/54"	84"	40 ½"	<b>07MT4254X84V2642</b>	8,898	9,418	448	628
2 (48") tops, 1 (6") Base	42"/54"	96"	40 ½"	<b>07MT4254X96V2642</b>	9,040	9,572	448	628

Order Code	Specification Information	Pricing Tiers
Example: <b>07MT4254X60V2630</b>	To order please specify pattern number including: 1. Top finish: ( ) 2. Base finish: ( ) 3. Power and connectivity (Optional, blank for none): <b>UMHW</b> Under-mount, Hardwire. <b>UMPI</b> Under-mount, Plug in. <b>UMLK</b> Under-mount, Linkable. <b>TSHW</b> Top-mount Small, Hardwired. <b>TSPI</b> Top-mount Small, Plug in. <b>TLHW</b> Top-mount Large, Hardwired. <b>TLPI</b> Top-mount Large, Plug in.	<b>TIP</b> = Tier 1 veneer top with painted base <b>T2P</b> = Tier 2 veneer top with painted bases <b>T1</b> = Upcharge from T1P for Tier 1 veneer bases <b>T2</b> = Upcharge from T2P for Tier 2 veneer bases
<b>07</b> JD Collection		Please refer to Materials and Finishes <a href="#">page 7</a> for specification details. Please refer to Accessories <a href="#">page 81</a> for specification details.
<b>MT</b> Media Table Trapezoid		
<b>4254X</b> Depth		
<b>60</b> Width		
<b>V</b> Veneer		
<b>2</b> 2" thick top		
<b>6</b> 6" wide base		
<b>30</b> Height		

**Application Notes**

Tables comes with only one base.  
 Under-mount and slide-out power is always Black.  
 Tables ship knocked-down, assembly required.  
 Tables come with structural metal aprons, finished in metallic black powder (MC12).  
 Wire management handled vertically through bases and horizontally through aprons.  
 Bases can fully or partially conceal a floor core, pending the application. This ability will vary based on type, size, location of the floor core.

Finish and grain matched on tables with multi-piece tops  
 Undermount power units finished in metallic black powder (MC12).  
 Tops pre-drilled for installation of undermount power.  
 Undermount power unit comes with (x1) dual AC hardwire (HW) or plug in(PI) power module and (x2) single space blank plates. For additional connectivity please contact sales person.  
 Top-mount power is available in 5 finishes:  
 Black = ECB  
 White = ECGW  
 Silver = ECS  
 Brushed Aluminum = ECAL  
 Stainless Steel = ECSS.

# Bookcase

## 29" and 35" High

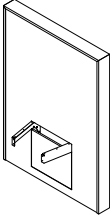
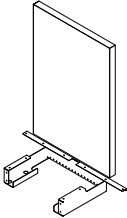
Type	W	H	Wall Thickness	Pattern No.	Tier 1	Tier 2	LIST
	30"H Table Full Wall	56 1/2"	72 1/2"	6 1/2"	<b>07MFSI57797</b>	\$10,389	\$10,586
	42"H Table Full Wall	56 1/2"	72 1/2"	6 1/2"	<b>07MFST57797</b>	10,389	10,586
	Partial Wall	24 1/2"	36"	2"	<b>07MPH24362</b>	3,075	3,257
	Wall Bracket				<b>07MBR</b>		\$1,000

Order Code	Specification Information	Pricing Tiers
Example: <b>07MPH24362</b>	To order please specify pattern number including:	<b>T1</b> = Tier 1 veneer <b>T2</b> = Tier 2 veneer
<b>07</b> JD Collection	1. Trim Finish	Media Wall bracket is only for the cantilever table mounted on an architectural wall. For the Full and Partial Media Wall, the bracket is included.
<b>MP</b> Media Partial Height Wall	2. Table Side Finish	
<b>24</b> Width	3. Other Side Finish	
<b>36</b> Height	Please refer to Materials and Finishes page for specification details.	
<b>2</b> Thickness		

# JD Collection Waterfall Tables



**DATESWEISER**

# General Specifications

## Waterfall Tables Product Overview

---

### Design Features Of Tables

- Panel Thickness: 3.000 " (For both 1- and 2-piece designs)
- Apron Height: 5.000 " (For both 1- and 2-piece designs)
- Veneer finishes only
- Height Adjustable Cable Access Covers on inside of End Panels



42H x 30D x 84W Waterfall Table (1-Piece)



42H x 42D x 120W Waterfall Table (2-Piece)



# General Specifications

## Waterfall Tables Table Construction

### Edge Profiles & Grain Direction

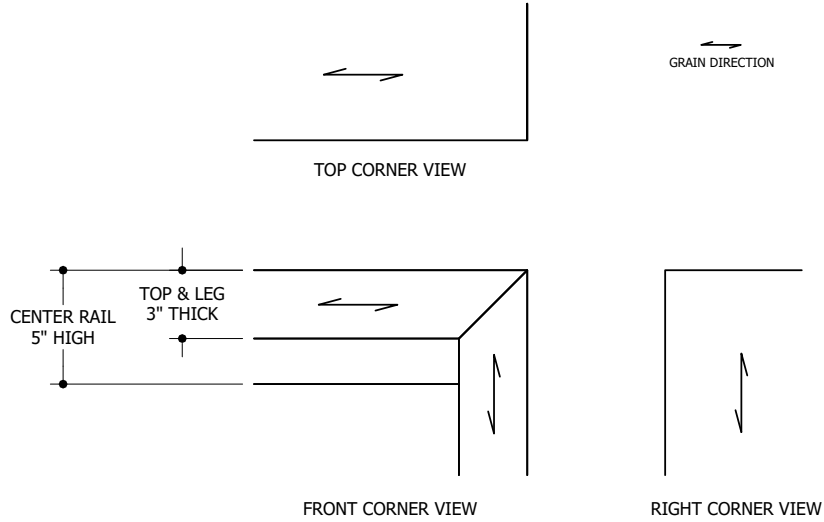

### Elevations, Splits & Cable Chase

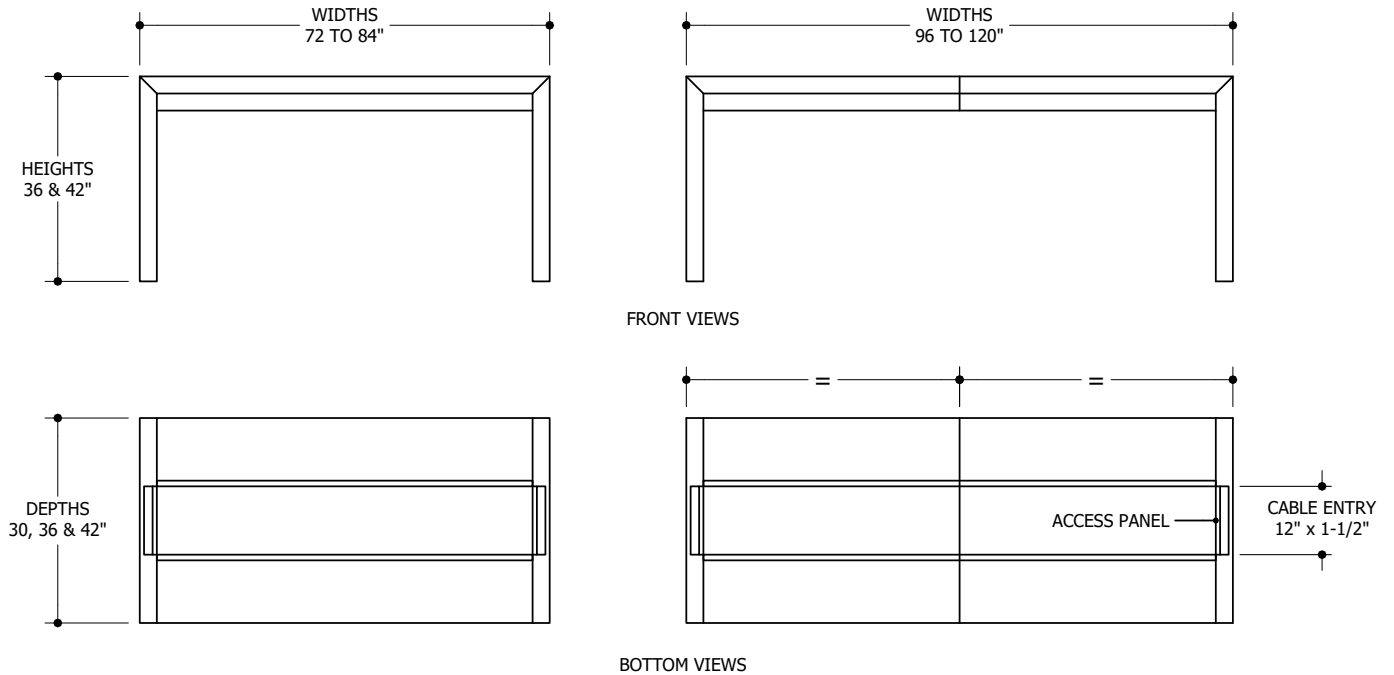

# General Specifications

## Waterfall Tables Power & Connectivity

### Power Unit Locations & Quantities by Width

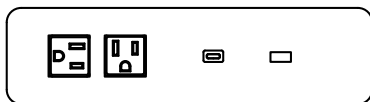
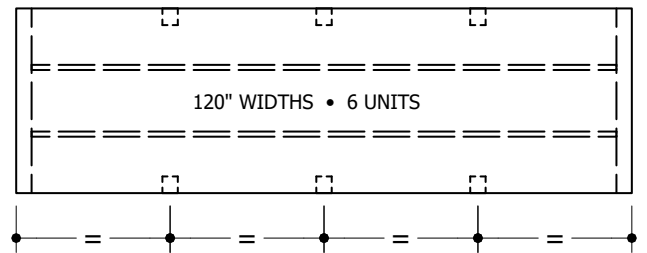
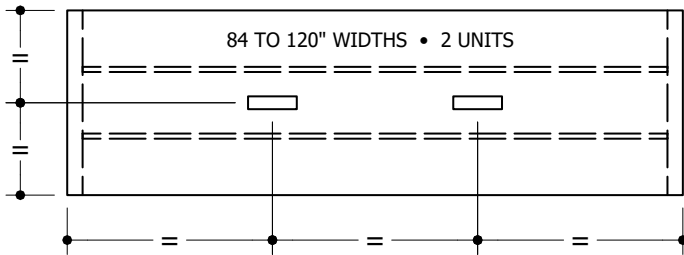
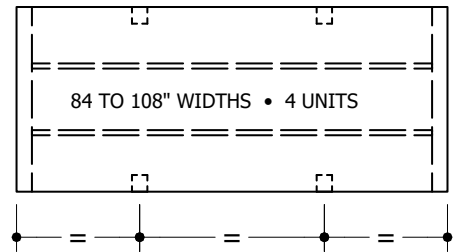
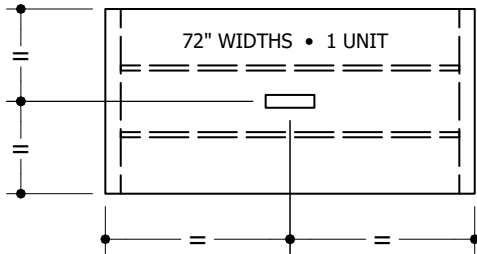
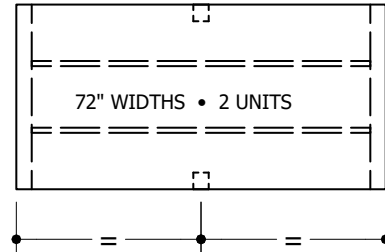

TOPMOUNT POWER  
AC + USB-A/C 60W



PERIMETER POWER  
USB-A/C 12\36W

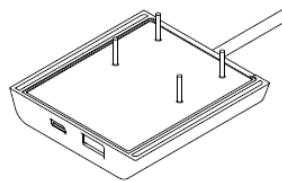
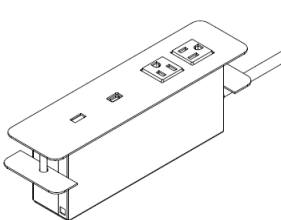



# General Specifications

## Waterfall Tables Power & Connectivity

---

### Topmount Cable Management w/ Power Connections at One End

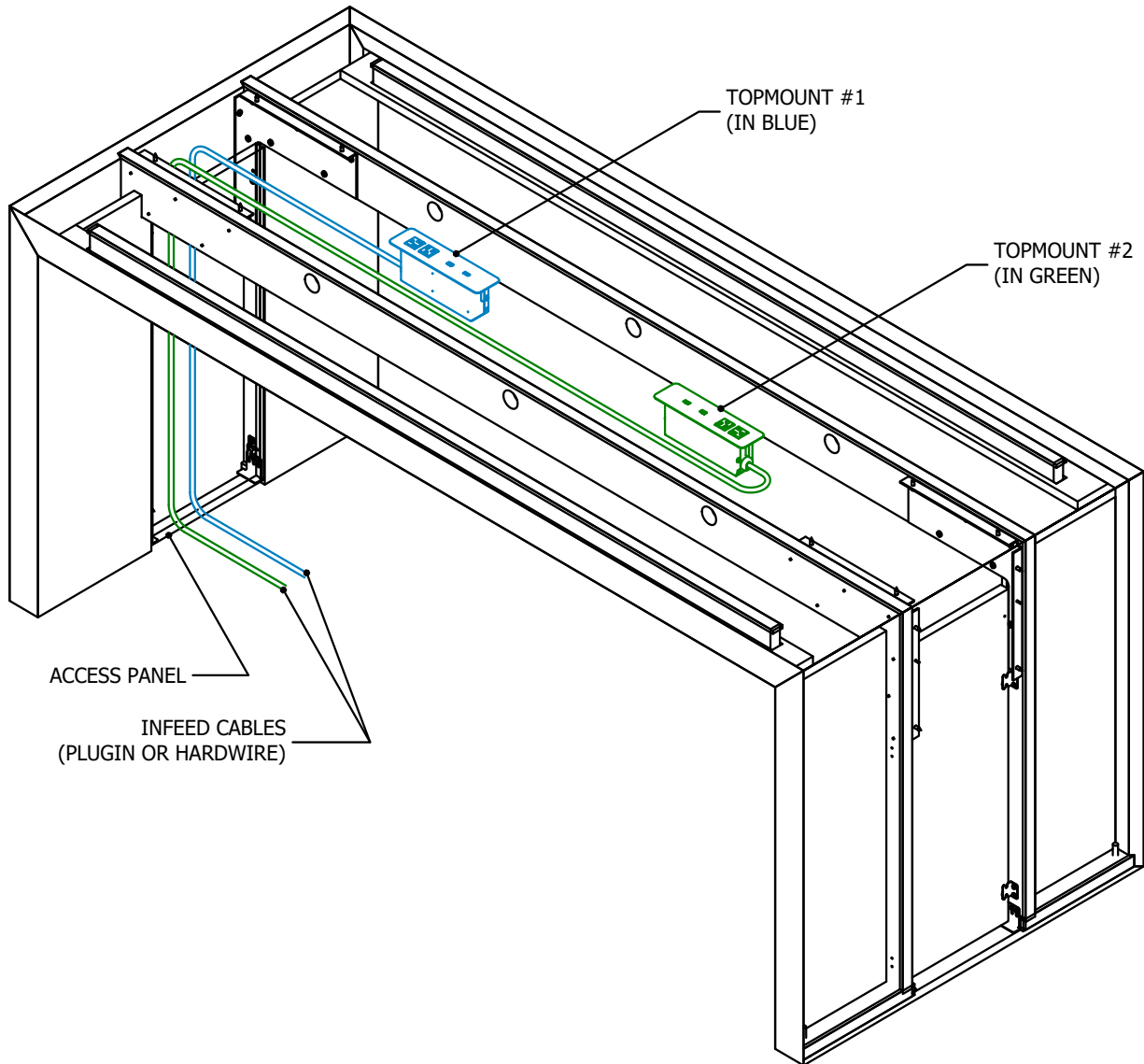

# General Specifications

## Waterfall Tables Power & Connectivity

---

### Topmount Cable Management w/ Power Connections at Both Ends

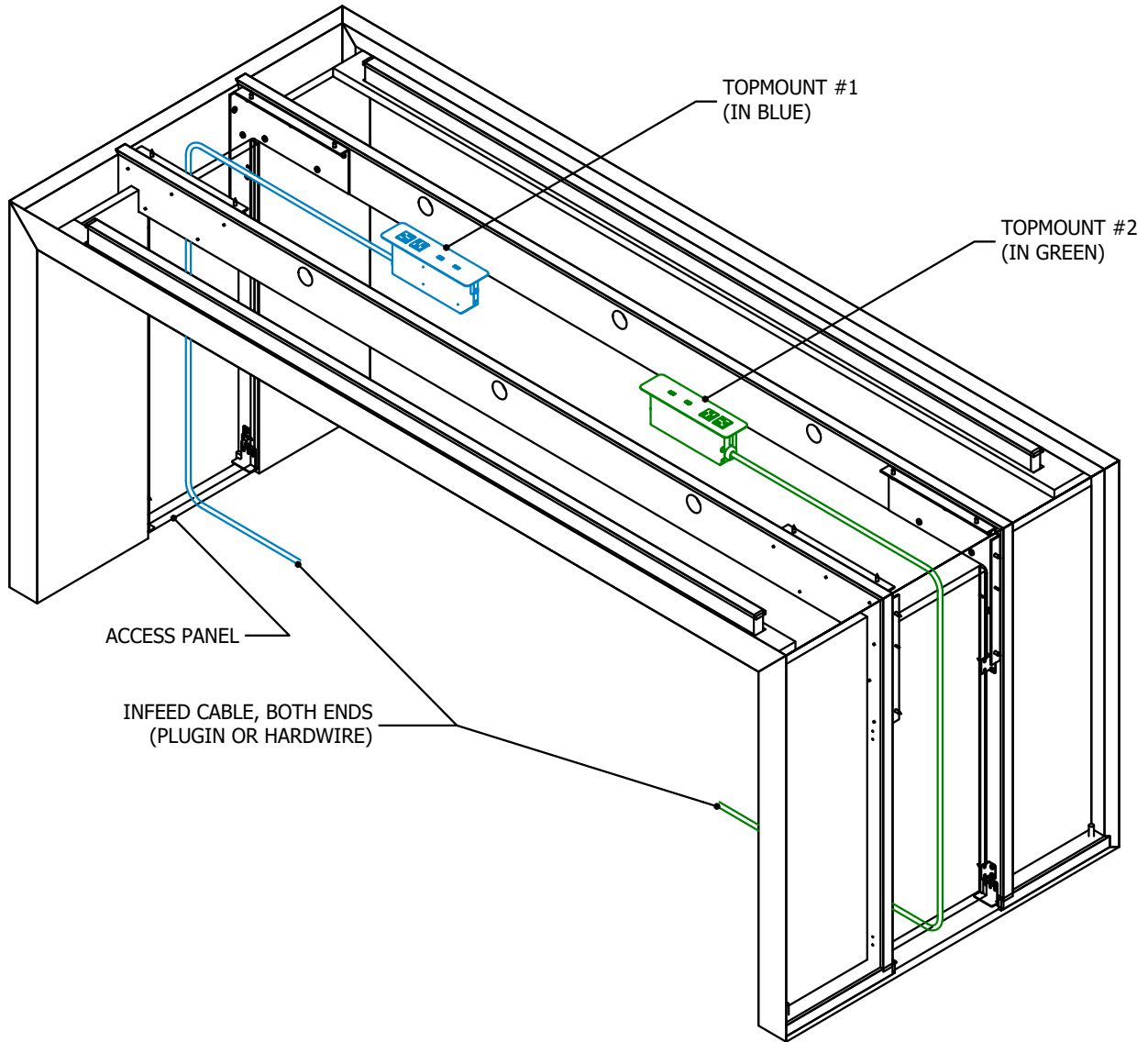

# General Specifications

## Waterfall Tables Power & Connectivity

---

### Topmount Cable Management w/ Power Bar or Junction Box

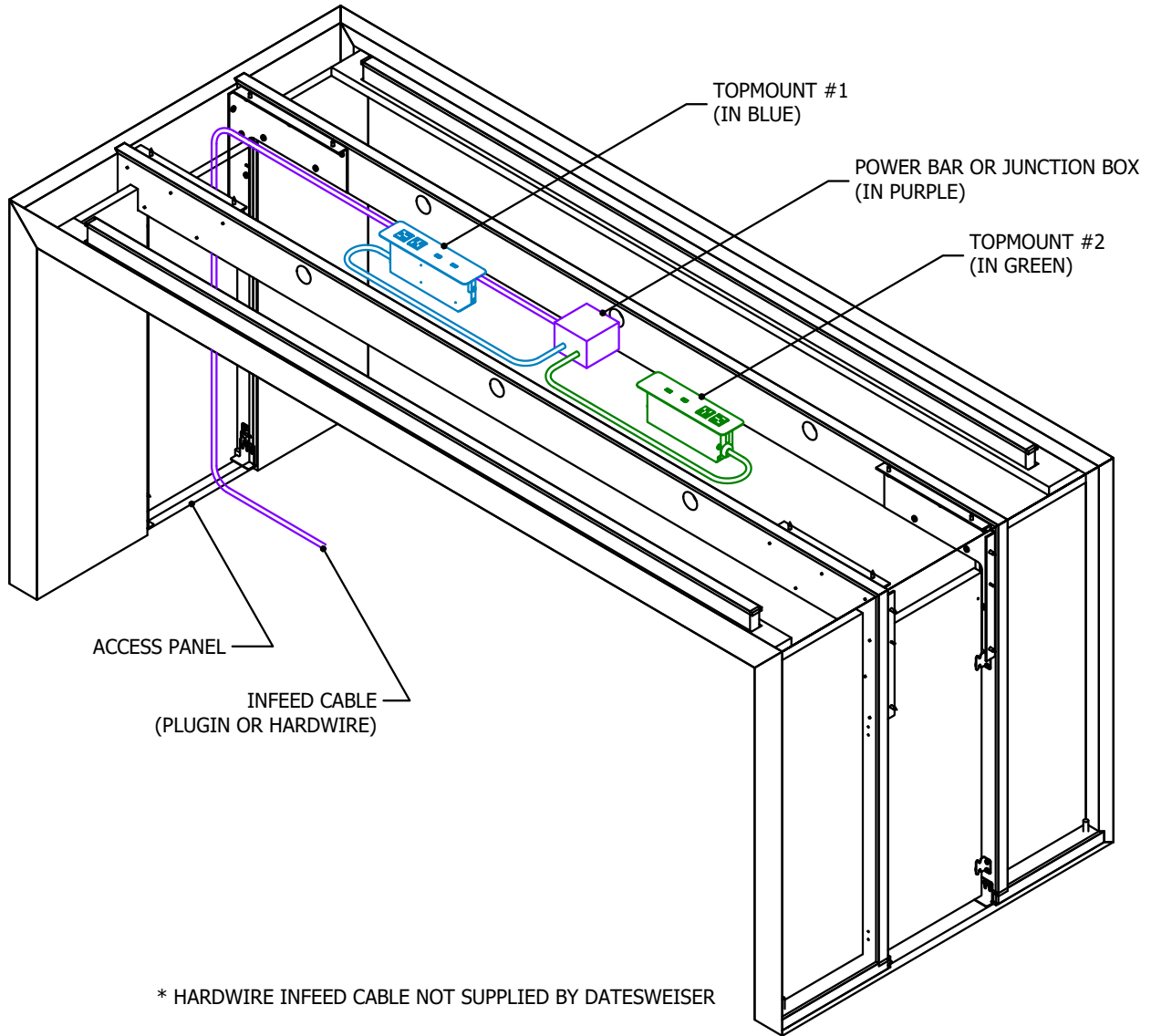

# General Specifications

## Waterfall Tables Power & Connectivity

### Perimeter USB Cable Management

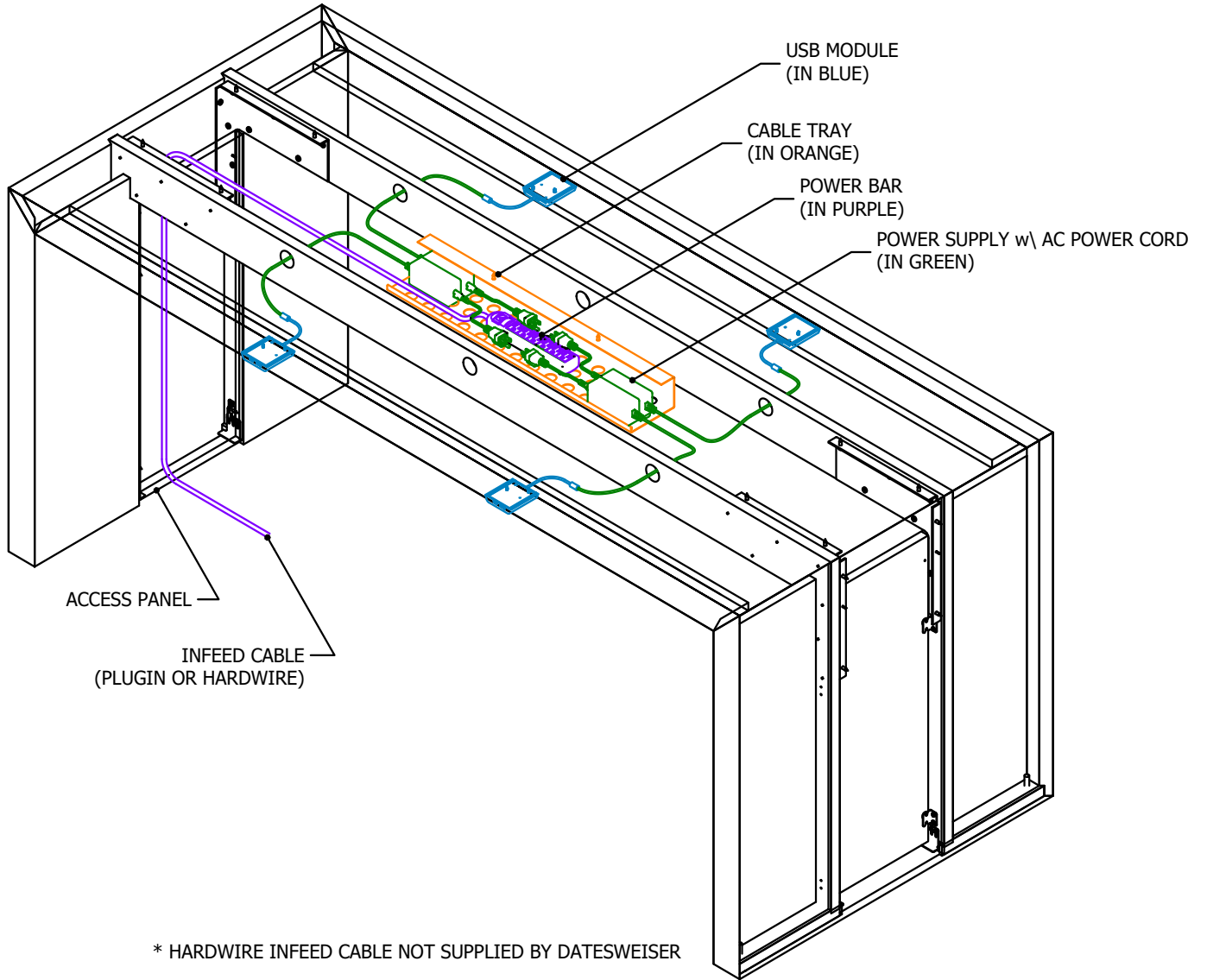



# Waterfall Tables

**30", 36" & 42" Deep, 36" High Counter Height**

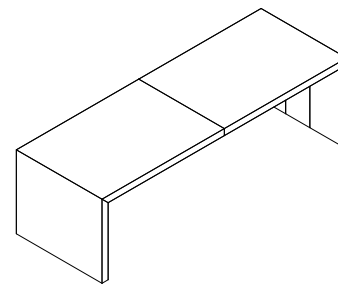

Type	D	W	H	Pattern No.	T1	T2
1 (72") Top	30"	72"	36"	<b>07WTM30X72V36</b>	\$9,300	\$9,858
1 (84") Top	30"	84"	36"	<b>07WTM30X84V36</b>	10,654	11,293
2 (48") Tops	30"	96"	36"	<b>07WTM30X96V36</b>	14,319	15,178
2 (54") Tops	30"	108"	36"	<b>07WTM30X108V36</b>	15,248	16,163
2 (60") Tops	30"	120"	36"	<b>07WTM30X120V36</b>	16,169	17,139
1 (72") Top	36"	72"	36"	<b>07WTM36X72V36</b>	10,971	11,629
1 (84") Top	36"	84"	36"	<b>07WTM36X84V36</b>	11,913	12,628
2 (48") Tops	36"	96"	36"	<b>07WTM36X96V36</b>	15,858	16,809
2 (54") Tops	36"	108"	36"	<b>07WTM36X108V36</b>	16,975	17,994
2 (60") Tops	36"	120"	36"	<b>07WTM36X120V36</b>	18,054	19,137
1 (72") Top	42"	72"	36"	<b>07WTM42X72V36</b>	12,089	12,814
1 (84") Top	42"	84"	36"	<b>07WTM42X84V36</b>	13,208	14,000
2 (48") Tops	42"	96"	36"	<b>07WTM42X96V36</b>	17,203	18,235
2 (54") Tops	42"	108"	36"	<b>07WTM42X108V36</b>	19,253	20,408
2 (60") Tops	42"	120"	36"	<b>07WTM42X120V36</b>	19,845	21,036

**Order Code**

Example:	<b>07WTM30X72V36</b>
<b>07</b>	JD Collection
<b>WTM</b>	Waterfall Table
<b>30X</b>	Depth
<b>72</b>	Width
<b>V</b>	Veneer
<b>36</b>	Height

**Specification Information**

To order please specify pattern number including:

1. Table (Veneer) finish: ( )
2. Power and connectivity: ( )
3. Topmount Finish (If Required)

**NP** No Power.  
**TMPI** Top-mount, Plug in.  
**TMHW** Top-mount, Hardwire.  
**PUPI** Perimeter USB Plug in.  
**PUHW** Perimeter USB Hardwire.

**Pricing Tiers**

**T1** = Tier 1 veneer  
**T2** = Tier 2 veneer

Please refer to Materials and Finishes [page 7](#) for specification details. Please refer to Accessories [page 81](#) for specification details.

# Waterfall Media Tables

**30", 36" & 42" Deep, 42" High Bar Height**

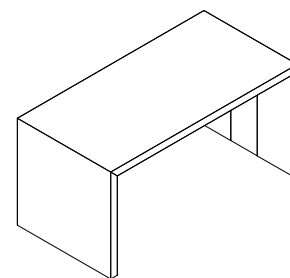

Type	D	W	H	Pattern No.	T1	T2
1 (72") Top	30"	72"	42"	<b>07WTM30X72V42</b>	\$9,996	\$10,596
1 (84") Top	30"	84"	42"	<b>07WTM30X84V42</b>	10,716	11,359
2 (48") Tops	30"	96"	42"	<b>07WTM30X96V42</b>	14,451	15,318
2 (54") Tops	30"	108"	42"	<b>07WTM30X108V42</b>	15,350	16,271
2 (60") Tops	30"	120"	42"	<b>07WTM30X120V42</b>	16,296	17,274
1 (72") Top	36"	72"	42"	<b>07WTM36X72V42</b>	11,142	11,811
1 (84") Top	36"	84"	42"	<b>07WTM36X84V42</b>	12,325	13,065
2 (48") Tops	36"	96"	42"	<b>07WTM36X96V42</b>	16,025	16,987
2 (54") Tops	36"	108"	42"	<b>07WTM36X108V42</b>	17,138	18,166
2 (60") Tops	36"	120"	42"	<b>07WTM36X120V42</b>	18,213	19,306
1 (72") Top	42"	72"	42"	<b>07WTM42X72V42</b>	12,290	13,027
1 (84") Top	42"	84"	42"	<b>07WTM42X84V42</b>	13,403	14,207
2 (48") Tops	42"	96"	42"	<b>07WTM42X96V42</b>	17,596	18,652
2 (54") Tops	42"	108"	42"	<b>07WTM42X108V42</b>	19,028	20,170
2 (60") Tops	42"	120"	42"	<b>07WTM42X120V42</b>	19,905	21,099

Order Code	Specification Information	Pricing Tiers
Example: <b>07WTM30X72V42</b>	To order please specify pattern number including:	<b>T1</b> = Tier 1 veneer <b>T2</b> = Tier 2 veneer
<b>07</b> JD Collection	1. Table (Veneer) finish: ( )	Please refer to Materials and Finishes <a href="#">page 7</a> for specification details. Please refer to Accessories <a href="#">page 81</a> for specification details.
<b>WTM</b> Waterfall Table	2. Power and connectivity: ( )	
<b>30X</b> Depth	3. Topmount Finish (If Required)	
<b>72</b> Width	<b>NP</b> No Power.	
<b>V</b> Veneer	<b>TMPI</b> Top-mount, Plug in.	
<b>42</b> Height	<b>TMHW</b> Top-mount, Hardwire.	
	<b>PUPI</b> Perimeter USB Plug in.	
	<b>PUHW</b> Perimeter USB Hardwire.	





# JD Collection Credenzas



**DATESWEISER**

# General Specifications

## Credenzas Product Overview

**Note:**

Line drawings in this price list are purely for quick product identification without form of detail and cannot be used to satisfy production dimensions, shape or support options. Refer to Planning Guide for detailed product information.

### BOOKCASE CREDENZA MATRIX

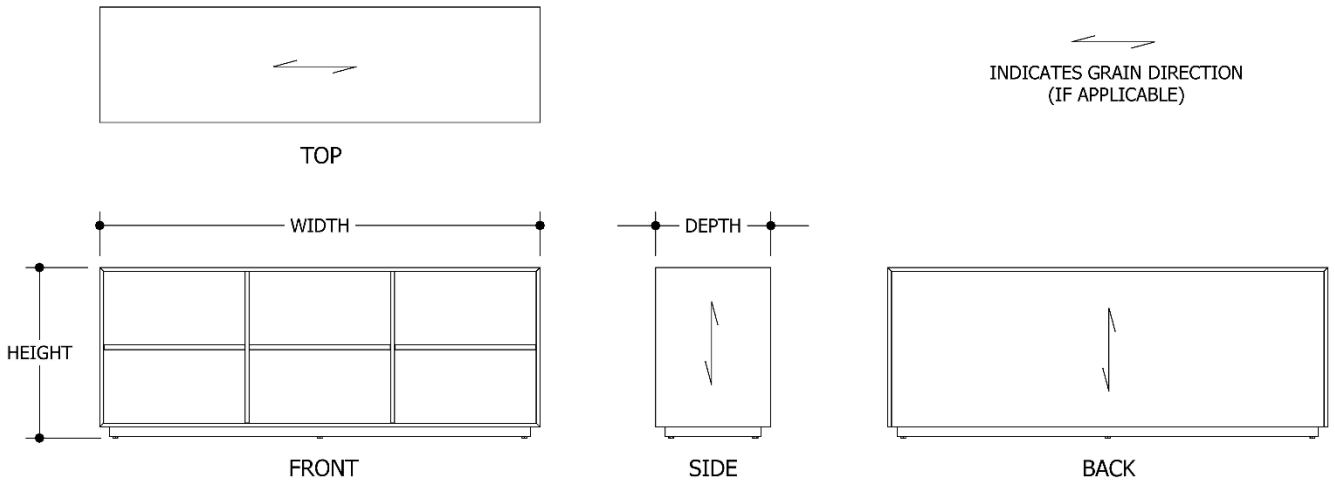

BOOKCASE ELEVATION SPECIFICATIONS

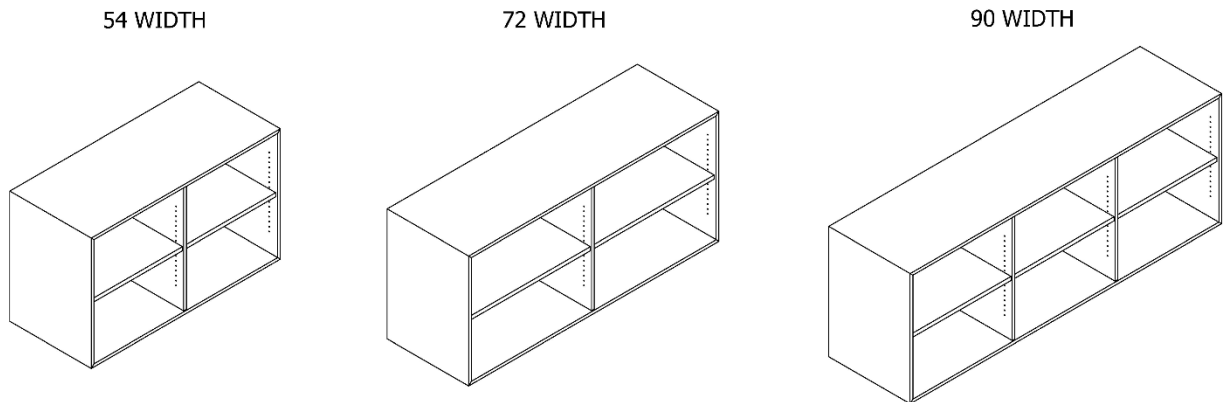

BOOKCASE CONFIGURATIONS

# General Specifications

## Credenzas

### Product Overview

---

#### Bookcase Construction Notes:

Top and end panels are 3/4" thick wood panels with mitred corners.

Bottom panel is a 3/4" thick wood panel that is butt-jointed to the end panels, but cleverly done to give the appearance of a mitred corner on the front.

Back panel is a 3/4" thick inset wood panel.

Back panel is picture-framed by the top and end panels exposing the mitred corners while the bottom panel set back and hidden from view behind the back panel.

Vertical divider panels are 3/4" thick wood panels.

Shelves are 1" thick wood panels and adjustable in 32 mm (1-1/4") increments with a nominal minimum clearance of 6" on top or bottom.

Bases are 2" high wood panels recessed 2" on all sides.

All components finished to match in either a veneer or satin lacquer finish.

# General Specifications

## Credenzas Product Overview

### MODULAR CREDENZA CASE MATRIX

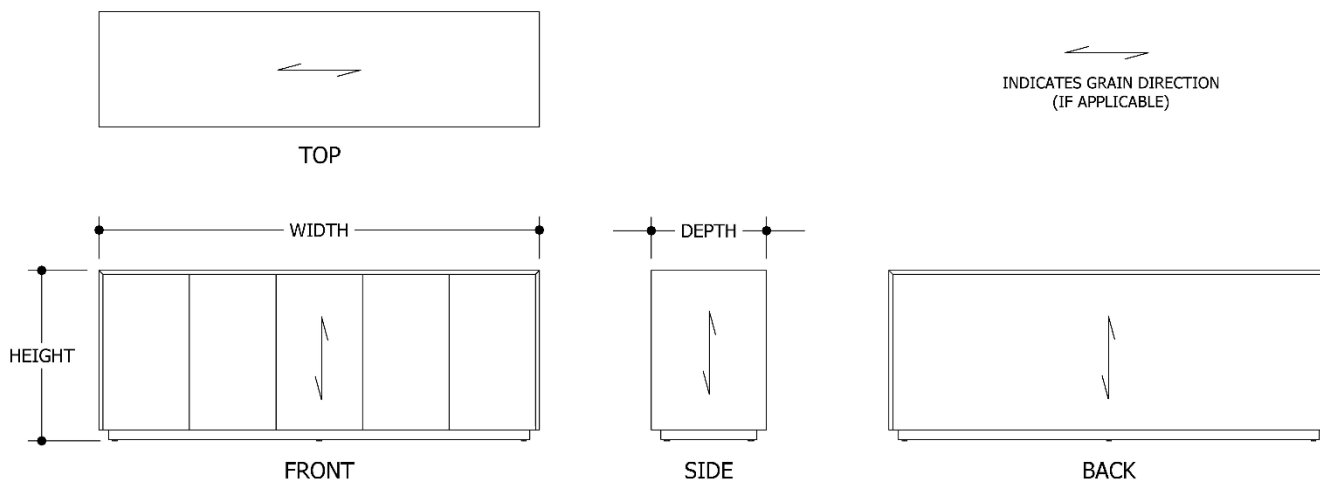

MODULAR CASE ELEVATION SPECIFICATIONS

54, 60 & 66 WIDTHS  
(3 INSERTS)

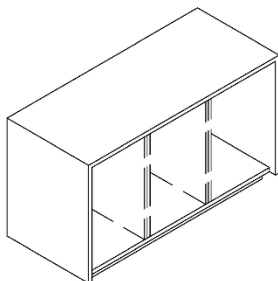

72, 78 & 84 WIDTHS  
(4 INSERTS)

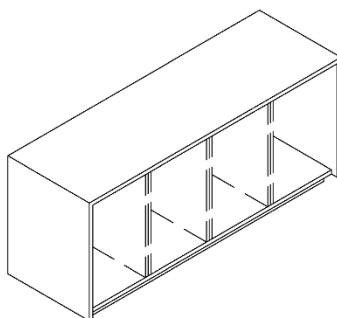

90, 96 & 102 WIDTHS  
(5 INSERTS)

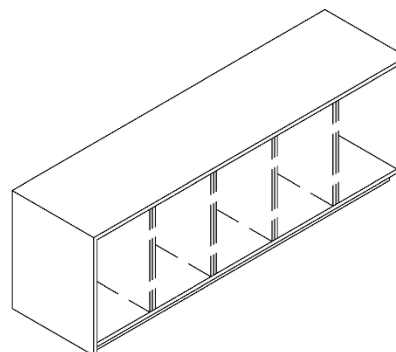

MODULAR CREDENZA CONFIGURATIONS

# General Specifications

## Credenzas

### Product Overview

---

#### Modular Case Construction Notes:

Top and end panels are 3/4" thick wood panels with mitred corners.

Bottom panel is a 3/4" thick wood panel that is butt-jointed to the end panels.

Bottom Panel is recessed and hidden behind drawer and door fronts.

Back panel is a 3/4" thick inset wood panel, picture-framed by the top and end panels exposing the mitred corners while the bottom panel is set back and hidden from view behind the back panel.

Bases are 2" high wood panels recessed 2" on all sides.

A\V Rack and/or Cool Drawer 24" wide insert positions are equipped with an 18" wide x 19" high cutout in the back panel as well as two 6" wide x 1" deep grommets along the front edge of the bottom panel for ventilation.



All components finished to match in either a veneer or satin lacquer finish.

# General Specifications

## Credenzas Product Overview

### MODULAR CREDENZA INSERT MATRIX

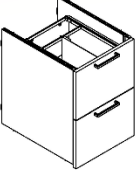
#### 29 HIGH MODULAR CREDENZA INSERT CONFIGURATIONS

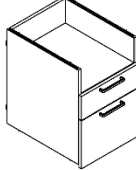
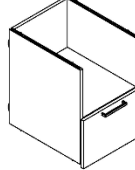
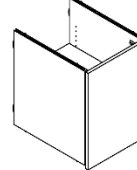
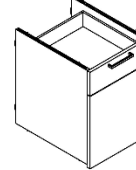
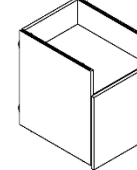
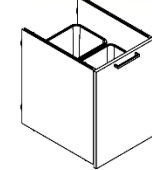
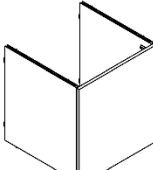
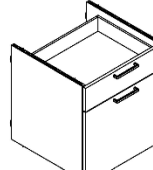
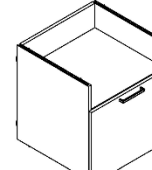
							
18FFMB	18FBBMB	18FBOMB	18FOMB	18HL 18HR	18HBLMB 18HBRMB	18HOL 18HOR	18TMB
FILE DRAWER FILE DRAWER	BOX DRAWER BOX DRAWER FILE DRAWER	OPEN SHELF BOX DRAWER FILE DRAWER	OPEN SHELF FILE DRAWER	HINGE DOOR *	BOX DRAWER HINGE DOOR *	OPEN SHELF HINGE DOOR *	PULL-OUT TRASH
  							
24AL 24AR AV HINGE DOOR *							
24CBMB BOX DRAWER COOL DRAWER							
24COMB OPEN SHELF COOL DRAWER							

#### 35 HIGH MODULAR CREDENZA INSERT CONFIGURATIONS

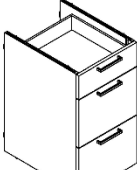
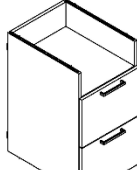
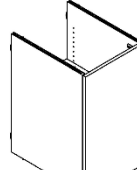
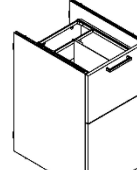
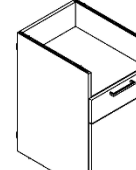
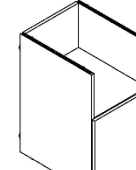
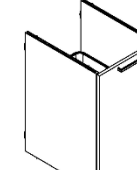
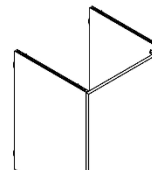
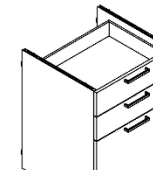
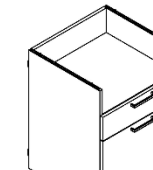
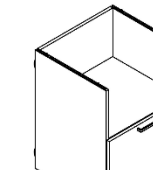
						
18FFBMB	18FFOMB	18HL 18HR	18HFL 18HFR	18HBOLMB 18HBORMB	18HOL 18HOR	18TMB
BOX DRAWER FILE DRAWER FILE DRAWER	OPEN SHELF FILE DRAWER FILE DRAWER	HINGE DOOR *	FILE DRAWER HINGE DOOR *	OPEN SHELF BOX DRAWER HINGE DOOR *	OPEN SHELF HINGE DOOR *	PULL-OUT TRASH
   						
24AL 24AR AV HINGE DOOR						
24CBMB BOX DRAWER BOX DRAWER COOL DRAWER						
24CBOMB OPEN SHELF BOX DRAWER COOL DRAWER						
24COMB OPEN SHELF COOL DRAWER						

# General Specifications

## Credenzas

### Product Overview

---

#### Insert Construction Notes:

End panels are 3/4" thick wood panels.

Horizontal divider panels are 3/4" thick wood panels.

Shelves are 1" thick wood panels and adjustable in 32 mm (1-1/4") increments with a nominal minimum clearance of 6" on top or bottom.

Drawer and door fronts are 3/4" thick wood panels.

Drawers constructed using 1/2" thick wood panels for the front, back and sides with a 3/16" thick wood bottom.

File and box drawers run on fully concealed, under-mounted, full-extension, soft-closing slides rated for 110 pounds per pair.

Drawers and pull-out trash are equipped with pulls.

Hinged doors use 110° free-swing hinges with touch-latch and no pulls.

Fronts are inset 1/4" from the front of the case, creating an iconic and unique aesthetic detail.

Interior components are finished to match the case in a veneer or satin lacquer finish.

Fronts can be specified with a different veneer or satin lacquer finish than the case.

# General Specifications

## Credenzas Product Overview

### CREDENZA KEY FEATURES

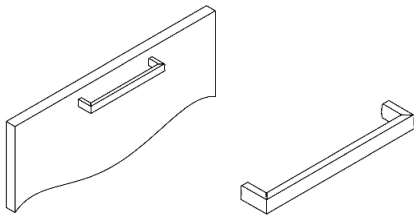
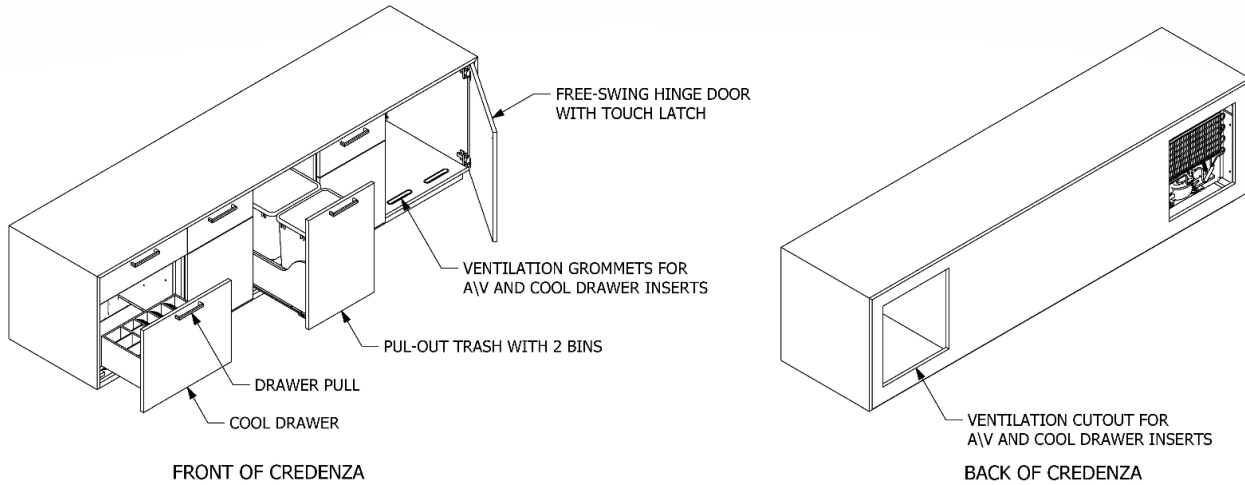

#### MITRED DRAWER PULL (MB)

##### AVAILABLE FINISHES:

- BRUSHED NICKLE (HBN)
- MATT BLACK (HMB)

##### DIMENSIONS:

- 6-5/8" WIDE x 1-1/8" DEEP x 1/2" HIGH

##### MOUNTING LOCATION ON DRAWERS AND DOORS:

- CENTRED ON WIDTH
- 1" DOWN FROM TOP OF FRONT TO CENTRE OF PULL

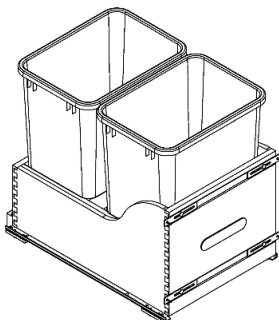

#### PULL-OUT TRASH

EQUIPPED WITH TWO 35-QUART WASTE CONTAINERS THAT RUN ON FULL-EXTENSION, SOFT-CLOSING SLIDES.

WOOD BOTTOM CONSTRUCTED USING 1/2" MAPLE PANELS.

TRASH BINS ARE CONSTRUCTED OF A BLACK POLYMER MATERIAL.



#### COOL DRAWER

SIZE CAPACITY OF 42L (1.48 Cu. Ft.) WITH 2 TRAYS...

- LARGE (LOWER) TRAY CAN HANDLE ITEMS SUCH AS BOTTLES AND CANS.
- SMALL (UPPER) TRAY IS PERFECT FOR SMALLER ITEMS LIKE MINI BOTTLES OR CONDIMENT PACKETS.

MAXIMUM COOLING CAPACITY OF 40°C (104°F)

REQUIRES A 120V CONNECTION FOR POWER.



# General Specifications

## Credenzas Product Overview

### SPECIFYING MODULAR CREDENZAS

STEP 1: THE CASE  
SELECT HEIGHT AND WIDTH OPTIONS

#### 3-POSITION CREDEENZA

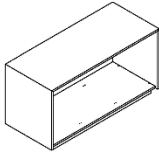

07CRM292456  
29H x 24D x 56W CREDEENZA CASE

#### 4-POSITION CREDEENZA

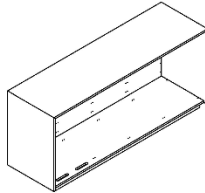

07CRM352480L  
35H x 24D x 86W CREDEENZA CASE  
w\ 24W VENTED POSITION ON LEFT

#### 5-POSITION CREDEENZA

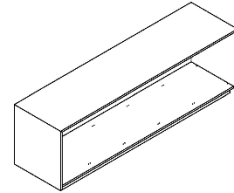

07CRM292492  
29H x 24D x 92W CREDEENZA CASE

STEP 2: THE INSERTS  
SELECT DESIRED CONFIGURATION

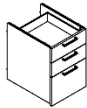

18FBBMB  
FILE\BOX\BOX  
QTY 2

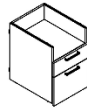

18FBOMB  
FILE\BOX\OPEN  
QTY 1

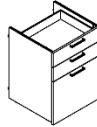

24CBBMB  
COOL DRAWER\BOX\BOX  
QTY 1



18FFOMB  
FILE\FILE\OPEN  
QTY 2

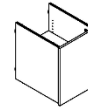

18HL  
HINGE DOOR LEFT  
QTY 1

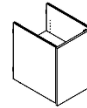

18HR  
HINGE DOOR RIGHT  
QTY 1

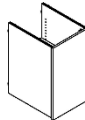

18HR  
HINGE DOOR RIGHT  
QTY 1

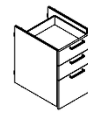

18FBBMB  
FILE\BOX\BOX  
QTY 2

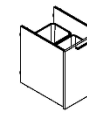

18TMB  
PULL-OUT TRASH  
QTY 1

STEP 3: THE PRODUCT  
CREDEENZA IS NOW FULLY SPECIFIED

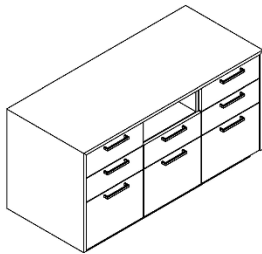

07CRM292456-18FBBMB-18FBOMB-18FBBMB  
29H x 24D x 56W CREDEENZA ASSEMBLY

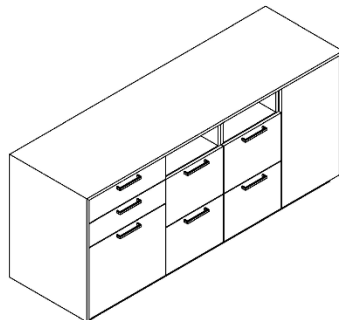

07CRM352480L-24CBBMB-18FFOMB-18FFOMB-18HR  
35H x 24D x 86W CREDEENZA ASSEMBLY

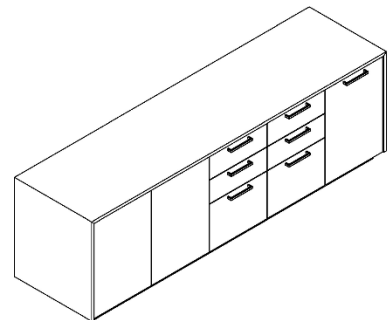

07CRM292492-18HL-18HR-18FBBMB-18FBBMB-18TMB  
29H x 24D x 92W CREDEENZA ASSEMBLY

# General Specifications

## Credenzas

### Product Overview

---

#### Application Notes

All credenzas are equipped with floor levelers to level the credenza.

No assembly required. All credenzas are shipped fully assembled.

Coordinate AV requirements with the interior overall clearance dimensions provided below to ensure proper fit. Consult with your AV contractor for specific component requirements. Custom solutions are available upon request.

For 29 high x 24" wide credenza insert:

25-1/16" height x 22-3/8" width x 21-15/16" depth

For 35 high x 24" wide credenza insert:

31-1/2" height x 22-3/8" width x 21-15/16" depth



# Bookcase

## 29" and 35" High

Credenzas

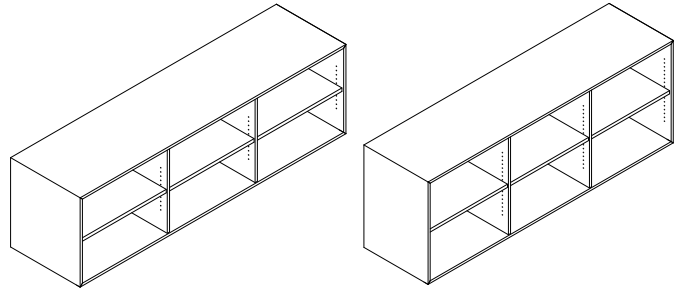

Description	Type	D	W	H	Pattern No.	Painted	T1	T2
Bookcase, 29" High	56" Wide	24"	56"	29"	<b>07CRB292456</b>	\$4,742	\$6,323	\$7,811
	74" Wide	24"	74"	29"	<b>07CRB292474</b>	5,534	7,386	9,263
	92" Wide	24"	92"	29"	<b>07CRB292492</b>	6,326	8,442	10,723

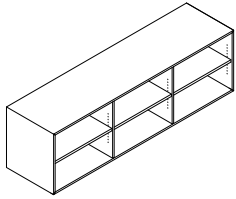

Bookcase, 35" High	56" Wide	24"	56"	35"	<b>07CRB352456</b>	5,162	6,853	8,497
	74" Wide	24"	74"	35"	<b>07CRB352474</b>	6,076	8,054	10,140
	92" Wide	24"	92"	35"	<b>07CRB352492</b>	6,991	9,265	11,780

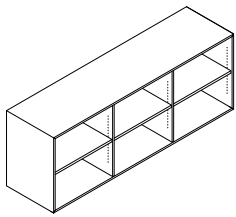

Order Code	Specification Information	Pricing Tiers
Example: <b>07CRB292456</b>	To order please specify pattern number including: 1. Case finish  Please refer to Materials and Finishes <a href="#">page 7</a> for specification details.	Painted Case <b>T1</b> = Tier 1 veneer case <b>T2</b> = Tier 2 veneer case
<b>07</b> JD Collection		
<b>CR</b> Credenza		
<b>B</b> Bookcase		
<b>29</b> 29" High		
<b>24</b> 24" Deep		
<b>56</b> 56" Wide		

Note that the credenzas are priced as modular components. The prices listed above are the case prices. The inserts are priced separately. Please refer to [page 75-78](#) for insert pricing.

### Application Notes

Construction:  
Top and end panels are 3/4" thick wood panels with mitered corners.  
Bottom panel is a 3/4" thick wood panel that is butt-jointed to the end panels, but cleverly done to give the appearance of a mitered corner on the front.  
Back panel is a 3/4" thick inset wood panel.  
Back panel is picture-framed by the top and end panels exposing the mitered corners while the bottom panel set back and hidden from view behind the back panel.

Vertical divider panels are 3/4" thick wood panels.  
Shelves are 1" thick wood panels and adjustable in 32 mm (1 1/4") increments with a nominal minimum clearance of 6" on top or bottom.  
Bases are 2" high wood panels recessed 2" on all sides.  
All components finished to match in either a veneer or satin lacquer finish.

# 3 Position Credenzas

29" High

Credenzas

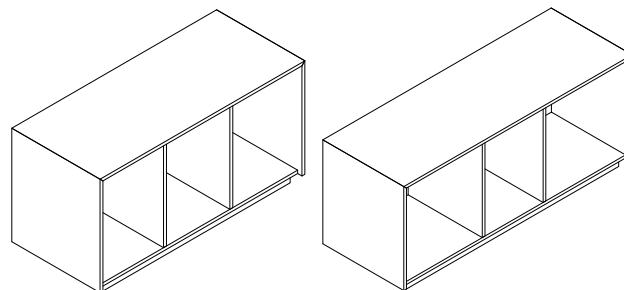

Description	Type	D	W	H	Pattern No.	Painted	T1	T2
3 Positions with File Drawer, Hinge Door, Pull Out-Trash & Box Drawers configuration options, 29" High	3 x 18" wide inserts	24"	55 3/4"	29"	<b>07CRM292456</b>	\$4,429	\$5,686	\$6,661

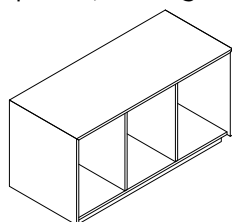

3 Positions with AV Hinge door, Cool Drawer, File Drawer, Hinge Door, Pull Out-Trash and Box Drawers configuration options, 29" High	1 x 18" insert & 2 x 24"w insert on both ends	24"	67 3/4"	29"	<b>07CRM292468</b>	4,887	6,256	7,385
	2 x 18" insert & 1 x 24"w insert on the left	24"	61 3/4"	29"	<b>07CRM292462L</b>	4,662	5,968	7,020
	2 x 18" insert & 1 x 24"w insert on the right	24"	61 3/4"	29"	<b>07CRM292462R</b>	4,662	5,968	7,020

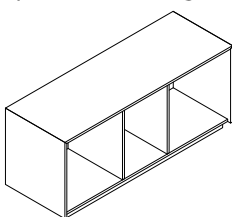

Order Code	Specification Information	Pricing Tiers
Example: <b>07CRM292456</b>	To order please specify pattern number including:	Painted Case
<b>07</b> JD Collection	1. Case finish	<b>T1</b> = Tier 1 veneer case
<b>CR</b> Credenza	2. Front finish	<b>T2</b> = Tier 2 veneer case
<b>M</b> Modular	3. Position 1/2/3 insert configuration	Pull Finish Options:
<b>29</b> 29" High	4. Pull Finish	HBN = Brushed Nickel
<b>24</b> 24" Deep	Positions are specified left to right. Please refer to <a href="#">page 75-78</a> for insert configuration codes.	HMB = Matt Black
<b>56</b> 56" Wide	Please refer to Materials and Finishes <a href="#">page 7</a> for specification details.	Note that the credenzas are priced as modular components. The prices listed above are the case prices. The inserts are priced separately. Please refer to <a href="#">page 75-78</a> for insert pricing.

### Application Notes

Construction:  
 Top and end panels are 3/4" thick wood panels with mitered corners.  
 Bottom panel is a 3/4" thick wood panel that is butt-jointed to the end panels.  
 Back panel is a 3/4" thick inset wood panel.  
 Back panel is picture-framed by the top and end panels exposing the mitered corners while the bottom panel set back and hidden from view behind the back panel.

Bases are 2" high wood panels recessed 2" on all sides.  
 A/V Rack and/or Cool Drawer 24" wide insert positions are equipped with an 18" wide x 19" high cutout in the back panel as well as two 6" wide x 1" deep grommets along the front edge of the bottom panel for ventilation.  
 All components finished to match in either a veneer or satin lacquer finish.

# 3 Position Credenzas

**35" High**

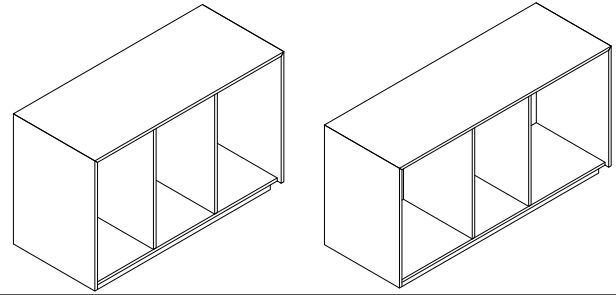

Description	Type	D	W	H	Pattern No.	Painted	T1	T2
3 Positions with File Drawer, Hinge Door, Pull Out-Trash & Box Drawers configuration options, 35" High	3 x 18" wide inserts	24"	55 3/4"	35"	<b>07CRM352456</b>	\$4,807	\$6,144	\$7,227

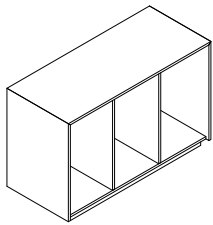

3 Positions with AV Hinge door, Cool Drawer, File Drawer, Hinge Door, Pull Out-Trash and Box Drawers configuration options, 35" High	1 x 18" insert & 2 x 24"w insert on both ends	24"	67 3/4"	35"	<b>07CRM352468</b>	5,340	6,794	8,039
	2 x 18" insert & 1 x 24"w insert on the left	24"	61 3/4"	35"	<b>07CRM352462L</b>	5,077	6,472	7,633
	2 x 18" insert & 1 x 24"w insert on the right	24"	61 3/4"	35"	<b>07CRM352462R</b>	5,077	6,472	7,633

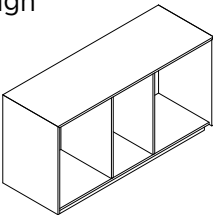

Order Code	Specification Information	Pricing Tiers
Example: <b>07CRM352456</b>	To order please specify pattern number including:	Painted Case
<b>07</b> JD Collection	1. Case finish	<b>T1</b> = Tier 1 veneer case
<b>CR</b> Credenza	2. Front finish	<b>T2</b> = Tier 2 veneer case
<b>M</b> Modular	3. Position 1/2/3 insert configuration	Pull Finish Options:
<b>35</b> 35" High	4. Pull Finish	HBN = Brushed Nickel
<b>24</b> 24" Deep	Positions are specified left to right. Please refer to <a href="#">page 75-78</a> for insert configuration codes.	HMB = Matt Black
<b>56</b> 56" Wide	Please refer to Materials and Finishes <a href="#">page 7</a> for specification details.	Note that the credenzas are priced as modular components. The prices listed above are the case prices. The inserts are priced separately. Please refer to <a href="#">page 75-78</a> for insert pricing.

**Application Notes**

Construction:  
 Top and end panels are 3/4" thick wood panels with mitered corners.  
 Bottom panel is a 3/4" thick wood panel that is butt-jointed to the end panels.  
 Back panel is a 3/4" thick inset wood panel.  
 Back panel is picture-framed by the top and end panels exposing the mitered corners while the bottom panel set back and hidden from view behind the back panel.

Bases are 2" high wood panels recessed 2" on all sides.  
 A/V Rack and/or Cool Drawer 24" wide insert positions are equipped with an 18" wide x 19" high cutout in the back panel as well as two 6" wide x 1" deep grommets along the front edge of the bottom panel for ventilation.  
 All components finished to match in either a veneer or satin lacquer finish.

# 4 Position Credenza

**29" High**

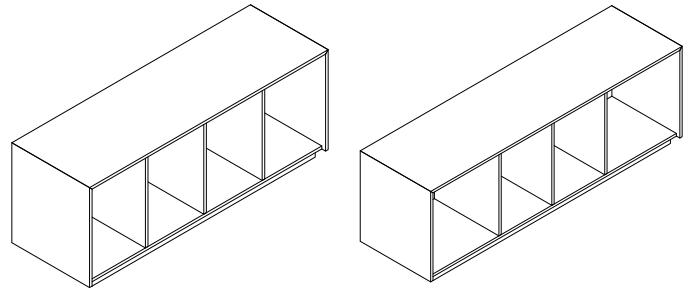

Description	Type	D	W	H	Pattern No.	Painted	T1	T2
4 Positions with File Drawer, Hinge Door, Pull Out-Trash & Box Drawers configuration options, 29" High	4 x 18" wide inserts	24"	73 3/4"	29"	<b>07CRM292474</b>	\$5,116	\$6,538	\$7,754

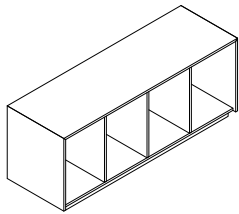

4 Positions with AV Hinge door, Cool Drawer, File Drawer, Hinge Door, Pull Out-Trash and Box Drawers configuration options, 29" High	2 x 18" insert & 2 x 24"w insert on both ends	24"	85 3/4"	29"	<b>07CRM292486</b>	5,580	7,106	8,472
	3 x 18" insert & 1 x 24"w insert on the left	24"	79 3/4"	29"	<b>07CRM292480L</b>	5,353	6,397	8,109
	3 x 18" insert & 1 x 24"w insert on the right	24"	79 3/4"	29"	<b>07CRM292480R</b>	5,353	6,397	8,109

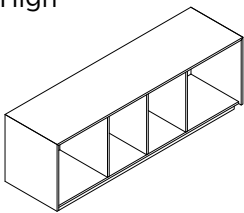

Order Code	Specification Information	Pricing Tiers
Example: <b>07CRM292474</b>	To order please specify pattern number including:	Painted Case
<b>07</b> JD Collection	1. Case finish	<b>T1</b> = Tier 1 veneer case
<b>CR</b> Credenza	2. Front finish	<b>T2</b> = Tier 2 veneer case
<b>M</b> Modular	3. Position 1/2/3/4 insert configuration	Pull Finish Options:
<b>29</b> 29" High	4. Pull Finish	HBN = Brushed Nickel
<b>24</b> 24" Deep	Positions are specified left to right. Please refer to <a href="#">page 75-78</a> for insert configuration codes.	HMB = Matt Black
<b>56</b> 74" Wide	Please refer to Materials and Finishes <a href="#">page 7</a> for specification details.	Note that the credenzas are priced as modular components. The prices listed above are the case prices. The inserts are priced separately. Please refer to <a href="#">page 75-78</a> for insert pricing.

### Application Notes

Construction:  
 Top and end panels are 3/4" thick wood panels with mitered corners.  
 Bottom panel is a 3/4" thick wood panel that is butt-jointed to the end panels.  
 Back panel is a 3/4" thick inset wood panel.  
 Back panel is picture-framed by the top and end panels exposing the mitered corners while the bottom panel set back and hidden from view behind the back panel.

Bases are 2" high wood panels recessed 2" on all sides.  
 A/V Rack and/or Cool Drawer 24" wide insert positions are equipped with an 18" wide x 19" high cutout in the back panel as well as two 6" wide x 1" deep grommets along the front edge of the bottom panel for ventilation.  
 All components finished to match in either a veneer or satin lacquer finish.

# 4 Position Credenzas

**35" High**

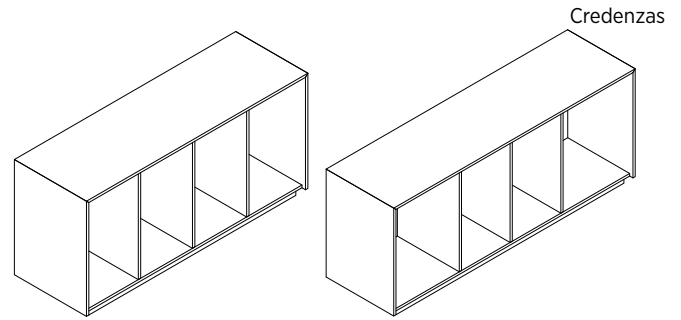

Description	Type	D	W	H	Pattern No.	Painted	T1	T2
4 Positions with File Drawer, Hinge Door, Pull Out-Trash & Box Drawers configuration options, 35" High	4 x 18" wide inserts	24"	73 3/4"	35"	<b>07CRM352474</b>	\$5,581	\$7,112	\$8,447

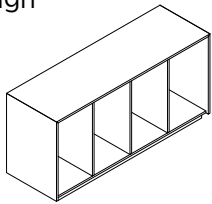

4 Positions with AV Hinge door, Cool Drawer, File Drawer, Hinge Door, Pull Out-Trash and Box Drawers configuration options, 35" High	2 x 18" insert & 2 x 24"w insert on both ends	24"	85 3/4"	35"	<b>07CRM352486</b>	6,146	7,776	9,274
	3 x 18" insert & 1 x 24"w insert on the left	24"	79 3/4"	35"	<b>07CRM352480L</b>	5,875	7,444	8,865
	3 x 18" insert & 1 x 24"w insert on the right	24"	79 3/4"	35"	<b>07CRM352480R</b>	5,875	7,444	8,865

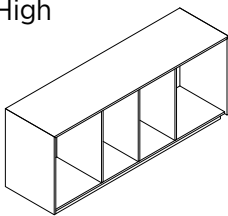

Order Code	Specification Information	Pricing Tiers
Example: <b>07CRM352474</b>	To order please specify pattern number including:	Painted Case
<b>07</b> JD Collection	1. Case finish	<b>T1</b> = Tier 1 veneer case
<b>CR</b> Credenza	2. Front finish	<b>T2</b> = Tier 2 veneer case
<b>M</b> Modular	3. Position 1/2/3/4 insert configuration	Pull Finish Options:
<b>35</b> 35" High	4. Pull Finish	HBN = Brushed Nickel
<b>24</b> 24" Deep	Positions are specified left to right. Please refer to <a href="#">page 75-78</a> for insert configuration codes.	HMB = Matt Black
<b>56</b> 74" Wide	Please refer to Materials and Finishes <a href="#">page 7</a> for specification details.	Note that the credenzas are priced as modular components. The prices listed above are the case prices. The inserts are priced separately. Please refer to <a href="#">page 75-78</a> for insert pricing.

### Application Notes

Construction:  
 Top and end panels are 3/4" thick wood panels with mitered corners.  
 Bottom panel is a 3/4" thick wood panel that is butt-jointed to the end panels.  
 Back panel is a 3/4" thick inset wood panel.  
 Back panel is picture-framed by the top and end panels exposing the mitered corners while the bottom panel set back and hidden from view behind the back panel.

Bases are 2" high wood panels recessed 2" on all sides.  
 A/V Rack and/or Cool Drawer 24" wide insert positions are equipped with an 18" wide x 19" high cutout in the back panel as well as two 6" wide x 1" deep grommets along the front edge of the bottom panel for ventilation.  
 All components finished to match in either a veneer or satin lacquer finish.



# 5 Position Credenza

29" High

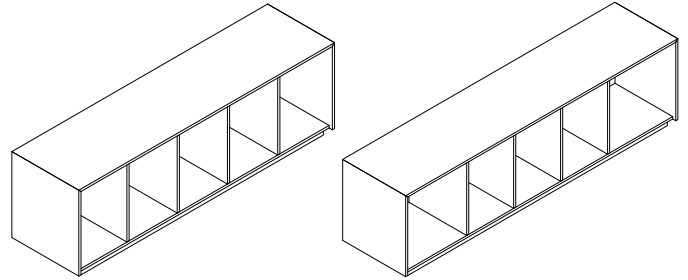

Description	Type	D	W	H	Pattern No.	Painted	T1	T2
5 Positions with File Drawer, Hinge Door, Pull Out-Trash & Box Drawers configuration options, 29" High	5 x 18" wide inserts	24"	91 3/4"	29"	<b>07CRM292492</b>	\$5,813	\$7,393	\$8,842

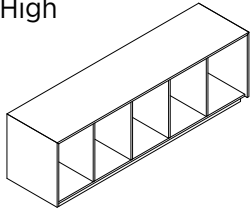

5 Positions with AV Hinge door, Cool Drawer, File Drawer, Hinge Door, Pull Out-Trash and Box Drawers configuration options, 29" High	3 x 18" insert & 2 x 24"w insert on both ends	24"	103 3/4"	29"	<b>07CRM2924104</b>	6,267	7,954	9,563
	4 x 18" insert & 1 x 24"w insert on the left	24"	97 3/4"	29"	<b>07CRM292498L</b>	6,039	7,673	9,204
	4 x 18" insert & 1 x 24"w insert on the right	24"	97 3/4"	29"	<b>07CRM292498R</b>	6,039	7,673	9,204

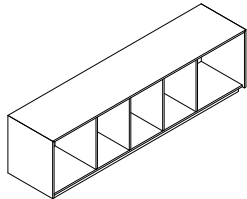

Order Code	Specification Information	Pricing Tiers
Example: <b>07CRM292492</b>	To order please specify pattern number including:	Painted Case
<b>07</b> JD Collection	1. Case finish	<b>T1</b> = Tier 1 veneer case
<b>CR</b> Credenza	2. Front finish	<b>T2</b> = Tier 2 veneer case
<b>M</b> Modular	3. Position 1/2/3/4/5 insert configuration	Pull Finish Options:
<b>29</b> 29" High	4. Pull Finish	HBN = Brushed Nickel
<b>24</b> 24" Deep	Positions are specified left to right. Please refer to <b>page 75-78</b> for insert configuration codes.	HMB = Matt Black
<b>92</b> 92" Wide	Please refer to Materials and Finishes <b>page 7</b> for specification details.	Note that the credenzas are priced as modular components. The prices listed above are the case prices. The inserts are priced separately. Please refer to <b>page 75-78</b> for insert pricing.

### Application Notes

Construction:  
 Top and end panels are 3/4" thick wood panels with mitered corners.  
 Bottom panel is a 3/4" thick wood panel that is butt-jointed to the end panels.  
 Back panel is a 3/4" thick inset wood panel.  
 Back panel is picture-framed by the top and end panels exposing the mitered corners while the bottom panel set back and hidden from view behind the back panel.

Bases are 2" high wood panels recessed 2" on all sides.  
 A/V Rack and/or Cool Drawer 24" wide insert positions are equipped with an 18" wide x 19" high cutout in the back panel as well as two 6" wide x 1" deep grommets along the front edge of the bottom panel for ventilation.  
 All components finished to match in either a veneer or satin lacquer finish.

# 5 Position Credenzas

**35" High**

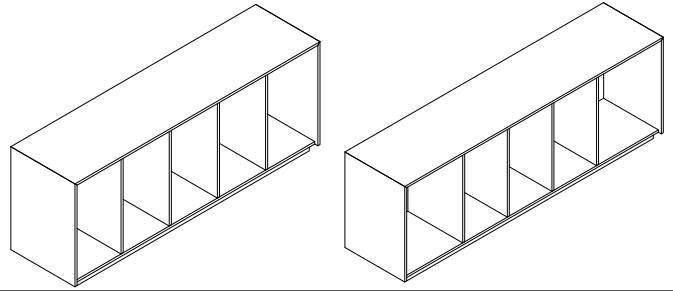

Description	Type	D	W	H	Pattern No.	Painted	T1	T2
5 Positions with File Drawer, Hinge Door, Pull Out-Trash & Box Drawers configuration options, 35" High	5 x 18" wide inserts	24"	91 3/4"	35"	<b>07CRM352492</b>	\$6,412	\$8,096	\$9,683

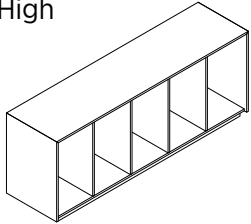

5 Positions with AV Hinge door, Cool Drawer, File Drawer, Hinge Door, Pull Out-Trash and Box Drawers configuration options, 35" High	3 x 18" insert & 2 x 24"w insert on both ends	24"	103 3/4"	35"	<b>07CRM3524104</b>	6,946	8,746	10,507
	4 x 18" insert & 1 x 24"w insert on the left	24"	97 3/4"	35"	<b>07CRM352498L</b>	6,684	8,415	10,101
	4 x 18" insert & 1 x 24"w insert on the right	24"	97 3/4"	35"	<b>07CRM352498R</b>	6,684	8,415	10,101

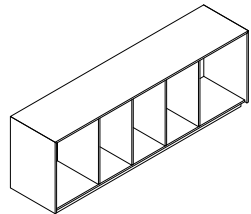

Order Code	Specification Information	Pricing Tiers
Example: <b>07CRM352492</b>	To order please specify pattern number including:	Painted Case
<b>07</b> JD Collection	1. Case finish	<b>T1</b> = Tier 1 veneer case
<b>CR</b> Credenza	2. Front finish	<b>T2</b> = Tier 2 veneer case
<b>M</b> Modular	3. Position 1/2/3/4/5 insert configuration	Pull Finish Options:
<b>35</b> 35" High	4. Pull Finish	HBN = Brushed Nickel
<b>24</b> 24" Deep	Positions are specified left to right. Please refer to <a href="#">page 75-78</a> for insert configuration codes.	HMB = Matt Black
<b>92</b> 92" Wide	Please refer to Materials and Finishes <a href="#">page 7</a> for specification details.	Note that the credenzas are priced as modular components. The prices listed above are the case prices. The inserts are priced separately. Please refer to <a href="#">page 75-78</a> for insert pricing.

**Application Notes**

Construction:  
 Top and end panels are 3/4" thick wood panels with mitered corners.  
 Bottom panel is a 3/4" thick wood panel that is butt-jointed to the end panels.  
 Back panel is a 3/4" thick inset wood panel.  
 Back panel is picture-framed by the top and end panels exposing the mitered corners while the bottom panel set back and hidden from view behind the back panel.

Bases are 2" high wood panels recessed 2" on all sides.  
 A/V Rack and/or Cool Drawer 24" wide insert positions are equipped with an 18" wide x 19" high cutout in the back panel as well as two 6" wide x 1" deep grommets along the front edge of the bottom panel for ventilation.  
 All components finished to match in either a veneer or satin lacquer finish.

# Credenza Inserts

**29" High**

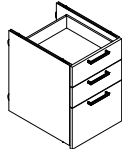
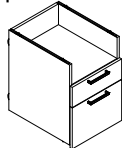
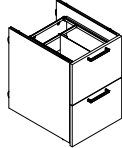
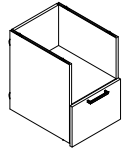
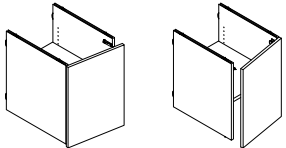
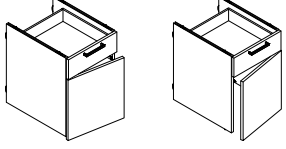
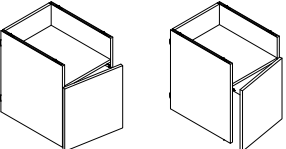
Description	Type	D	W	H	Pattern No.	Painted	T1	T2
1 x File Drawer & 2 x Box Drawer 	29"h insert	24"	18"	29"	<b>18FBBMB</b>	\$1,619	\$1,841	\$1,960
1 x File Drawer & 1 x Box Drawer & 1 x Open Shelf 	29"h insert	24"	18"	29"	<b>18FBOMB</b>	1,487	1,718	1,838
2 x File Drawer 	29"h insert	24"	18"	29"	<b>18FFMB</b>	1,479	1,697	1,816
1 x File Drawer & 1 x Open Shelf 	29"h insert	24"	18"	29"	<b>18FOMB</b>	1,303	1,534	1,653
1 x Hinged Door 	29"h insert	24"	18"	29"	<b>18H(L/R)</b>	1,131	1,362	1,481
1 x Hinged Door & 1 x Box Drawer 	29"h insert	24"	18"	29"	<b>18HB(L/R)MB</b>	1,315	1,546	1,666
1 x Hinged Door & 1 x Open Shelf 	29"h insert	24"	18"	29"	<b>18HO(L/R)</b>	1,131	1,362	1,481

# Credenza Inserts

## 29" High

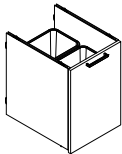
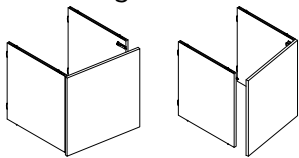
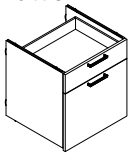
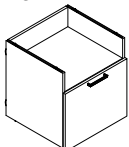
Description	Type	D	W	H	Pattern No.	Painted	T1	T2
1 x Pull-Out Trash 	29"h insert	24"	18"	29"	<b>18TMB</b>	1,594	1,824	1,945
1 x AV Hinged Door 	29"h insert	24"	24"	29"	<b>24A(L/R)</b>	1,176	1,407	1,526
1 x Refrigerator Drawer & 1 x Box Drawer 	29"h insert	24"	24"	29"	<b>24CBMB</b>	4,544	4,781	4,895
1 x Refrigerator Drawer & 1 x Open Shelf 	29"h insert	24"	24"	29"	<b>24COMB</b>	4,544	4,781	4,895

### Specification Information

The above insert configuration codes are included in the pattern string of the modular credenzas on pages 46 to 56. Note that insert configuration prices should be added onto 3-position, 4-position and 5-position case prices.

### Application Notes

End panels are 3/49 thick wood panels.  
 Horizontal divider panels are 3/49 thick wood panels.  
 Shelves are 1" thick wood panels and adjustable in 32 mm (1 1/4") increments with a nominal minimum clearance of 6" on top or bottom.  
 Drawer and door fronts are 3/4" thick wood panels.  
 Drawers constructed using 1/2" thick wood panels for the front, back and sides with a 3/16" thick wood bottom.  
 File and box drawers run on fully concealed, under-mounted, full-extension, soft-closing slides rated for 110 pounds per pair.

### Pricing Tiers

Painted Case  
 T1 = Tier 1 veneer case  
 T2 = Tier 2 veneer case

Drawers and pull-out trash are equipped with pulls.  
 Hinged doors use 110" free-swing hinges with touch-latch and no pulls.  
 Fronts are inset 1/4" from the front of the case, creating an iconic and unique aesthetic detail.  
 Fronts can be specified with a different veneer or satin lacquer finish then the case.  
 Interior components are finished to match the front in a veneer or satin lacquer finish.

# Credenza Inserts

**35" High**

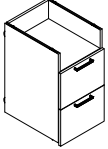
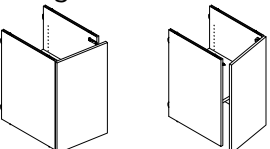
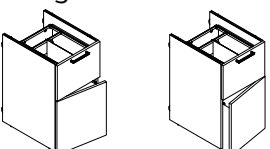
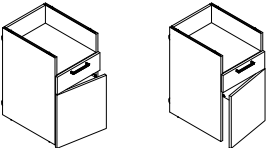
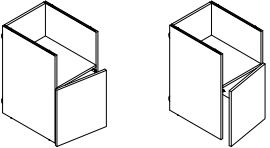
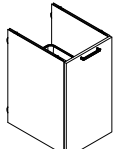
Description	Type	D	W	H	Pattern No.	Painted	T1	T2
2 x File Drawer & 1 x Box Drawer 	35"h insert	24"	18"	35"	<b>18FFBMB</b>	\$1,710	\$1,946	\$2,090
2 x File Drawer & 1 x Open Shelf 	35"h insert	24"	18"	35"	<b>18FFOMB</b>	1,525	1,761	1,903
1 x Hinged Door 	35"h insert	24"	18"	35"	<b>18H(L/R)</b>	1,173	1,421	1,560
1 x Hinged Door & 1 x File Drawer 	35"h insert	24"	18"	35"	<b>18HF(L/R)MB</b>	1,408	1,662	1,806
1 x Hinged Door & 1 x Box Drawer & 1 x Open Shelf 	35"h insert	24"	18"	35"	<b>18HBO(L/R)MB</b>	1,367	1,620	1,760
1 x Hinged Door & 1 x Open Shelf 	35"h insert	24"	18"	35"	<b>18HO(L/R)</b>	1,181	1,436	1,580
1 x Pull-Out Trash 	35"h insert	24"	18"	35"	<b>18TMB</b>	1,642	1,899	2,036

# Credenza Inserts

**35" High**

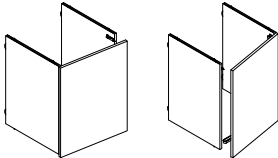
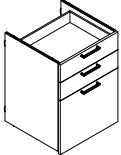
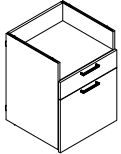
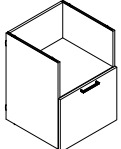
Description	Type	D	W	H	Pattern No.	Painted	T1	T2
1 x AV Hinged Door 	35"h insert	24"	24"	35"	<b>24A(L/R)</b>	1,234	1,462	1,604
1 x Refrigerator Drawer & 2 x Box Drawer 	35"h insert	24"	24"	35"	<b>24CBBMB</b>	4,945	5,199	5,341
1 x Refrigerator Drawer & 1 x Box Drawer & 1 x Open Shelf 	35"h insert	24"	24"	35"	<b>24CBOMB</b>	4,762	5,017	5,158
1 x Refrigerator Drawer & 1 x Open Shelf 	35"h insert	24"	24"	35"	<b>24COMB</b>	4,575	4,834	4,974

**Specification Information**

The above insert configuration codes are included in the pattern string of the modular credenzas on pages 46 to 56. Note that insert configuration prices should be added onto 3-position, 4-position and 5-position case prices.

**Application Notes**

End panels are 3/49 thick wood panels.  
 Horizontal divider panels are 3/49 thick wood panels.  
 Shelves are 1" thick wood panels and adjustable in 32 mm (1 1/4") increments with a nominal minimum clearance of 6" on top or bottom.  
 Drawer and door fronts are 3/4" thick wood panels.  
 Drawers constructed using 1/2" thick wood panels for the front, back and sides with a 3/16" thick wood bottom.  
 File and box drawers run on fully concealed, under-mounted, full-extension, soft-closing slides rated for 110 pounds per pair.

**Pricing Tiers**

Painted Case  
 T1 = Tier 1 veneer case  
 T2 = Tier 2 veneer case

Drawers and pull-out trash are equipped with pulls.  
 Hinged doors use 110" free-swing hinges with touch-latch and no pulls.  
 Fronts are inset 1/4" from the front of the case, creating an iconic and unique aesthetic detail.  
 Fronts can be specified with a different veneer or satin lacquer finish then the case.  
 Interior components are finished to match the front in a veneer or satin lacquer finish.



# Accessories



Power & Connectivity  
Undermount Unit  
For Conference & Media Tables

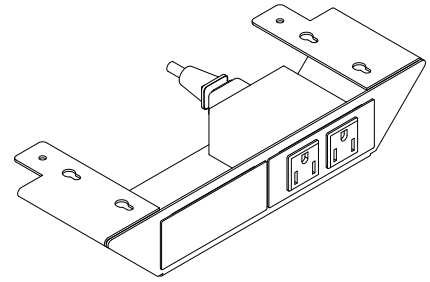

Pattern No.	Description	LIST
UMHW	Undermount Hardwired QTY 1	\$1,227
UMPI	Undermount Plug In QTY 1	\$892
UMLK	Undermount Linkable QTY 1	\$892

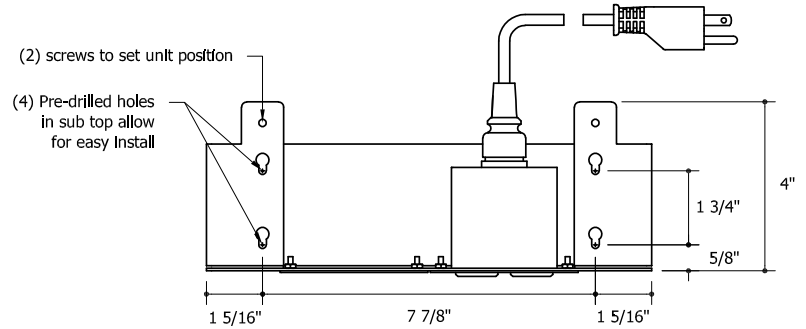
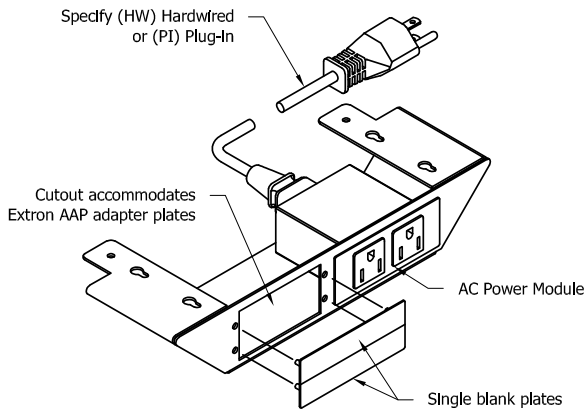

- Interior: Black powder coat metallic finish (MC12)
- Provided with 1 AC power module - specify hardwired (HW) or plug in (PI), and 2 single space blank plates
- For additional connectivity, please contact sale rep.

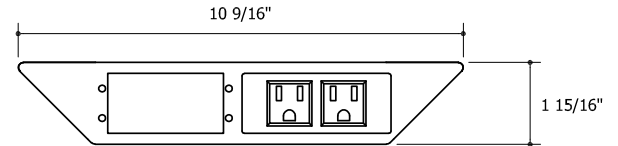

- Undermount access (shown populated)
- Provided with 1 AC power module - specify hardwired (HW) or plug in (PI), and 2 single space blank plates
  - For additional connectivity please contact sale rep.

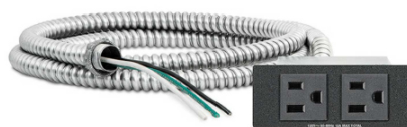
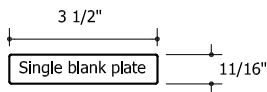

- AC Module Hardwired (HW)
- 3/8" diameter x 6' long metal-clad cable with 6" pigtail
  - Additional knockouts for series wiring
  - 12A max per module



- AC Module Plug In (PI)
- 7.5' detachable soft cord
  - 6A max per module

Power & Connectivity  
Table Top Small  
For Media Tables

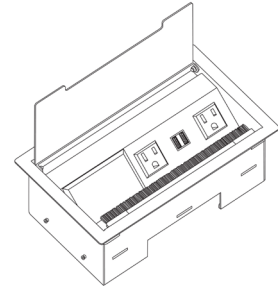

Pattern No.	Description	LIST
TSHW	Topmount Small Hardwired QTY 1	\$1,279
TSPI	Topmount Small Plug In QTY 1	\$1,243

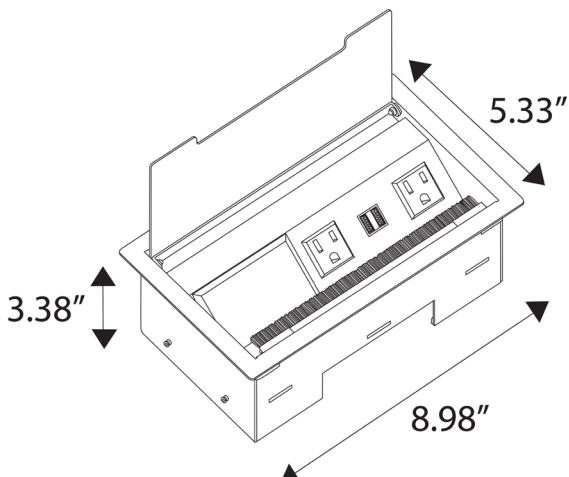

Power & Connectivity  
Table Top Large  
For Media Tables

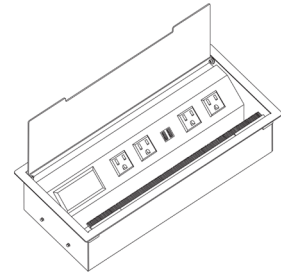

Pattern No.	Description	LIST
TLHW	Topmount Large Hardwired QTY 1	\$1,746
TLPI	Topmount Large Plug In QTY 1	\$1,711

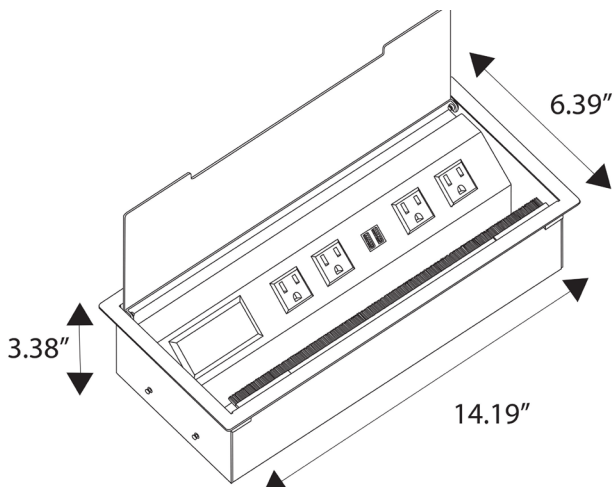

Power & Connectivity  
Top Mount  
For Waterfall Tables

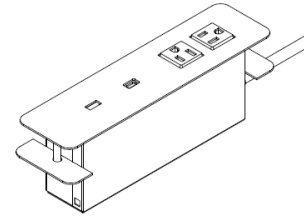

Pattern No.	Description	LIST
TMHW	Topmount Hardwired QTY 1	\$826
TMPI	Topmount Plug In QTY 1	\$826

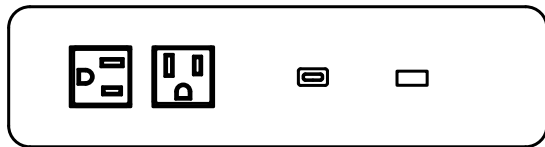

TOPMOUNT POWER  
AC + USB-A\C 60W



Power & Connectivity  
Perimeter USB  
For Waterfall Tables

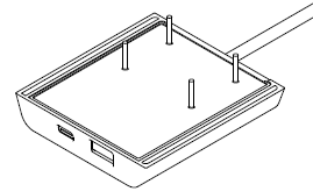

Pattern No.	Description	LIST
PUHW	Perimeter USB Hardwired QTY 1	\$538
PUPI	Perimeter USB Plug In QTY 1	\$494



PERIMETER POWER  
USB-A\C 12\36W



